

KENDRIYA VIDYALAYA SANGATHAN
CHENNAI REGION

STUDY MATERIAL

HOTS - QUESTIONS & SOLUTIONS

CLASS - X

MATHEMATICS

2008-09

**KENDRIYA VIDYALAYA SANGATHAN
CHENNAI REGION**



STUDY MATERIAL

**HOTS - QUESTIONS
& SOLUTIONS**

CLASS - X

MATHEMATICS

2008-09

*Mathematics is an independent world
Created out of pure intelligence.*

STUDY MATERIAL PREPRATION TEAM 2008-09

PATRON

1. Dr. E. Prabhakar Assistant commissioner KVS (RO)
Chennai

CONVENOR

1. Shri. P,Devakumar Education Officer, KVS (RO)
Chennai.

CO-ORDINATOR

1. Mrs. C.M. Sreekumari Principal KV Gill Nagar
Chennai.

PARTICIPANTS

1. Mrs. R.Bhuvaneswari TGT (Maths) KV Island Grounds
Chennai.

2.. Mr. S.K.Kannan TGT (Maths) KV Island Grounds
Chennai.

COMPUTER ASSISTANTS

1. Mr. S.K.Kannan TGT (Maths) KV Island Grounds, Chennai

2.Mrs. R.Bhuvaneswari TGT (Maths) KV Island Grounds, Chennai

3.Mr.Aarif Ahmed Computer Instructor KV Gill Nagar, Chennai

4. Mr. CH. Venugopala Rao PGT (Comp. Sci) KV, Gill Nagar, Chennai

5. Mrs. Priya Janaki Raman Computer Instructor KV, Island Grounds, Chennai

Our Sincere thanks to

1. Mr. Murugesan, TGT (Maths), KV Island Grounds, Chennai.
2. Mrs. Jayalakshmi, TGT (Maths), KV Island Grounds, Chennai.
3. Mrs. R. Sumathi, TGT (Maths), KV Island Grounds, Chennai.
4. Mrs. Usha, TGT (Maths), KV Gill Nagar, Chennai.

PREFACE

“God is a child; and when he began to play, he cultivated mathematics. It is the most godly of man's games”

Good Education is defined as acquiring skills. There are many different ways to be educated and many subjects that can be studied. A good education is one that teaches a student to think.

Mathematics develops logic and skill of reasoning among students. Focus of this material is primarily to strengthen the mind to absorb the concepts and bring in the students the required self-confidence while learning the subject. Math should be learnt with interest and it is made simple and approachable.

The material is a supplement to the curriculum and arranged in a chronological manner as published in textbook. As per CBSE examination pattern Higher Order Thinking Skills questions with solutions can be found in each chapter. This will definitely facilitate students to approach examinations with ease and confidence.

And finally, let the students remember that success is 1% inspiration and 99% perspiration. Hard work can never fail and will certainly help them reap rich rewards. Success will then become a habit for them.

“Seeing much, suffering much, and studying much, are the three pillars of learning”

“Learning is a treasure that will follow its owner everywhere.”

WE WISH ALL THE STUDENTS THE VERY BEST

CONTENTS

Chapter No.	Chapter Name	Page No.
1	NUMBER SYSTEMS	1-5
2	POLYNOMIALS	6-12
3	PAIR OF LINEAR EQUATIONS IN TWO VARIABLES	13-22
4	QUADRATIC EQUATIONS	23-29
5	ARITHMETIC PROGRESSIONS	30-37
6	TRIGONOMETRY	38-43
	HEIGHTS & DISTANCES	44-54
7	CO-ORDINATE GEOMETRY	55-61
8	SIMILAR TRIANGLES	62-69
9	CIRCLES	70-78
10	CONSTRUCTIONS	79
11	MENSURATION (AREAS RELATED TO CIRCLES)	80-87
12	PROBLEMS BASED ON CONVERSION OF SOLIDS	88-95
13	STATISTICS & PROBABILITY	96-110

NUMBER SYSTEMS

Numbers are intellectual witnesses that belong only to mankind.

1. If the H C F of 657 and 963 is expressible in the form of $657x + 963y - 15$ find x .
(Ans: $x=22$)

Ans: Using Euclid's Division Lemma

$$a = bq + r, \quad 0 \leq r < b$$

$$963 = 657 \times 1 + 306$$

$$657 = 306 \times 2 + 45$$

$$306 = 45 \times 6 + 36$$

$$45 = 36 \times 1 + 9$$

$$36 = 9 \times 4 + 0$$

$$\therefore \text{HCF}(657, 963) = 9$$

$$\text{now } 9 = 657x + 963y \quad (-15)$$

$$657x = 9 + 963y \times 15$$

$$= 9 + 14445y$$

$$657x = 14454y$$

$$x = 14454y / 657$$

$x = 22$

2. Express the GCD of 48 and 18 as a linear combination. (Ans: Not unique)

$$A = bq + r, \text{ where } 0 \leq r < b$$

$$48 = 18 \times 2 + 12$$

$$18 = 12 \times 1 + 6$$

$$12 = 6 \times 2 + 0$$

$$\therefore \text{HCF}(18, 48) = 6$$

$$\text{now } 6 = 18 - 12 \times 1$$

$$6 = 18 - (48 - 18 \times 2)$$

$$6 = 18 - 48 \times 1 + 18 \times 2$$

$$6 = 18 \times 3 - 48 \times 1$$

$$6 = 18 \times 3 + 48 \times (-1)$$

i.e. $6 = 18x + 48y$

$$\therefore \quad \boxed{x=3, y=-1}$$

$$\begin{aligned}
6 &= 18 \times 3 + 48 \times (-1) \\
&= 18 \times 3 + 48 \times (-1) + 18 \times 48 - 18 \times 48 \\
&= 18(3+48) + 48(-1-18) \\
&= 18 \times 51 + 48 \times (-19) \\
6 &= 18x + 48y
\end{aligned}$$

$$\therefore \boxed{x = 51, y = -19}$$

Hence, x and y are not unique.

3. Prove that one of every three consecutive integers is divisible by 3.

Ans:

$n, n+1, n+2$ be three consecutive positive integers
We know that n is of the form $3q, 3q+1, 3q+2$
So we have the following cases

Case – I when $n = 3q$

In the this case, n is divisible by 3 but $n + 1$ and $n + 2$ are not divisible by 3

Case - II When $n = 3q + 1$

Sub $n + 2 = 3q + 1 + 2 = 3(q + 1)$ is divisible by 3. but n and $n+1$ are not divisible by 3

Case – III When $n = 3q + 2$

Sub $n + 1 = 3q + 2 + 1 = 3(q + 1)$ is divisible by 3. but n and $n+2$ are not divisible by 3

Hence one of $n, n + 1$ and $n + 2$ is divisible by 3

4. Find the largest possible positive integer that will divide 398, 436, and 542 leaving remainder 7, 11, 15 respectively.
(Ans: 17)

Ans: The required number is the HCF of the numbers

Find the HCF of 391, 425 and 527 by Euclid's algorithm

$$\therefore \text{HCF}(425, 391) = 17$$

Now we have to find the HCF of 17 and 527

$$527 = 17 \times 31 + 0$$

$$\therefore \text{HCF}(17, 527) = 17$$

$$\therefore \text{HCF}(391, 425 \text{ and } 527) = 17$$

5. Find the least number that is divisible by all numbers between 1 and 10 (both inclusive).

(Ans:2520)

Ans: The required number is the LCM of 1,2,3,4,5,6,7,8,9,10

$$\therefore \text{LCM} = 2 \times 2 \times 3 \times 2 \times 3 \times 5 \times 7 = 2520$$

6. Show that 571 is a prime number.

Ans: Let $x=571 \Rightarrow \sqrt{x}=\sqrt{571}$

Now 571 lies between the perfect squares of $(23)^2$ and $(24)^2$

Prime numbers less than 24 are 2,3,5,7,11,13,17,19,23

Since 571 is not divisible by any of the above numbers

571 is a prime number

7. If d is the HCF of 30, 72, find the value of x & y satisfying $d = 30x + 72y$.

(Ans:5, -2 (Not unique))

Ans: Using Euclid's algorithm, the HCF (30, 72)

$$72 = 30 \times 2 + 12$$

$$30 = 12 \times 2 + 6$$

$$12 = 6 \times 2 + 0$$

$$\text{HCF}(30, 72) = 6$$

$$6 = 30 - 12 \times 2$$

$$6 = 30 - (72 - 30 \times 2) \times 2$$

$$6 = 30 - 2 \times 72 + 30 \times 4$$

$$6 = 30 \times 5 + 72 \times -2$$

$$\therefore x = 5, y = -2$$

$$\text{Also } 6 = 30 \times 5 + 72(-2) + 30 \times 72 - 30 \times 72$$

Solve it, to get

$$x = 77, y = -32$$

Hence, x and y are not unique

8. Show that the product of 3 consecutive positive integers is divisible by 6.

Ans: Proceed as in question sum no. 3

9. Show that for odd positive integer to be a perfect square, it should be of the form $8k + 1$.

Let $a = 2m + 1$

Ans: Squaring both sides we get

$$a^2 = 4m(m + 1) + 1$$

\therefore product of two consecutive numbers is always even

$$m(m+1) = 2k$$

$$a^2 = 4(2k) + 1$$

$$a^2 = 8k + 1$$

Hence proved

10. Find the greatest number of 6 digits exactly divisible by 24, 15 and 36.

(Ans: 999720)

Ans: LCM of 24, 15, 36

$$\text{LCM} = 3 \times 2 \times 2 \times 2 \times 3 \times 5 = 360$$

Now, the greatest six digit number is 999999

Divide 999999 by 360

$$\therefore Q = 2777, R = 279$$

\therefore the required number = $999999 - 279 = 999720$

11. If a and b are positive integers. Show that $\sqrt{2}$ always lies between $\frac{a}{b}$ and $\frac{a-2b}{a+b}$

Ans: We do not know whether $\frac{a^2 - 2b^2}{b(a+b)}$ or $\frac{a}{b} < \frac{a+2b}{a+b}$

\therefore to compare these two number,

$$\text{Let us compute } \frac{a}{b} - \frac{a+2b}{a+b}$$

$$\Rightarrow \text{on simplifying, we get } \frac{a^2 - 2b^2}{b(a+b)}$$

$$\therefore \frac{a}{b} - \frac{a+2b}{a+b} > 0 \text{ or } \frac{a}{b} - \frac{a+2b}{a+b} < 0$$

$$\text{now } \frac{a}{b} - \frac{a+2b}{a+b} > 0$$

$$\frac{a^2 - 2b^2}{b(a+b)} > 0 \text{ solve it, we get, } a > \sqrt{2}b$$

Thus, when $a > \sqrt{2}b$ and

$$\frac{a}{b} < \frac{a+2b}{a+b},$$

We have to prove that $\frac{a+2b}{a+b} < \sqrt{2} < \frac{a}{b}$

Now $a > \sqrt{2}b \Rightarrow 2a^2 + 2b^2 > 2b^2 + a^2 + 2b^2$

On simplifying we get

$$\sqrt{2} > \frac{a+2b}{a+b}$$

Also $a > \sqrt{2}b$

$$\Rightarrow \frac{a}{b} > \sqrt{2}$$

Similarly we get $\sqrt{2} < \frac{a+2b}{a+b}$

$$\text{Hence } \frac{a}{b} < \sqrt{2} < \frac{a+2b}{a+b}$$

12. Prove that $(\sqrt{n-1} + \sqrt{n+1})$ is irrational, for every $n \in \mathbb{N}$

Self Practice

POLYNOMIALS

It is not once nor twice but times without number that the same ideas make their appearance in the world.

1. Find the value for K for which $x^4 + 10x^3 + 25x^2 + 15x + K$ exactly divisible by $x + 7$.

(Ans : K= -91)

Ans: Let $P(x) = x^4 + 10x^3 + 25x^2 + 15x + K$ and $g(x) = x + 7$

Since $P(x)$ exactly divisible by $g(x)$

$\therefore r(x) = 0$

$$\begin{array}{r}
 \text{now } x + 7 \overline{) x^4 + 10x^3 + 25x^2 + 15x + K} \\
 \underline{x^4 + 7x^3} \\
 3x^3 + 25x^2 \\
 \underline{3x^3 + 21x^2} \\
 4x^2 + 15x \\
 \underline{4x^2 + 28x} \\
 -13x + K \\
 \underline{-13x - 91} \\
 K + 91 \\
 \hline
 \end{array}$$

$\therefore K + 91 = 0$

K = -91

2. If two zeros of the polynomial $f(x) = x^4 - 6x^3 - 26x^2 + 138x - 35$ are $2 \pm \sqrt{3}$. Find the other zeros. (Ans: 7, -5)

Ans: Let the two zeros are $2 + \sqrt{3}$ and $2 - \sqrt{3}$

Sum of Zeros = $2 + \sqrt{3} + 2 - \sqrt{3}$
 $= 4$

Product of Zeros = $(2 + \sqrt{3})(2 - \sqrt{3})$
 $= 4 - 3$
 $= 1$

Quadratic polynomial is $x^2 - (\text{sum})x + \text{Product}$

$$\begin{array}{r}
 x^2 - 2x - 35 \\
 \hline
 x^2 - 4x + 1 \Big) x^4 - 6x^3 - 26x^2 + 138x - 35 \\
 \underline{x^4 - 4x^3 + x^2} \\
 -2x^3 - 27x^2 + 138x \\
 \underline{-2x^3 + 8x^2 - 2x} \\
 -35x^2 + 140x - 35 \\
 \underline{-35x^2 + 140x - 35} \\
 0
 \end{array}$$

$$\begin{aligned}
 \therefore x^2 - 2x - 35 &= 0 \\
 (x - 7)(x + 5) &= 0 \\
 x &= 7, -5
 \end{aligned}$$

other two Zeros are 7 and -5

3. Find the Quadratic polynomial whose sum and product of zeros are $\sqrt{2} + 1, \frac{1}{\sqrt{2} + 1}$.

Ans: sum = $2\sqrt{2}$
Product = 1
Q.P =
 $X^2 - (\text{sum})x + \text{Product}$

$$\therefore x^2 - (2\sqrt{2})x + 1$$

4. If α, β are the zeros of the polynomial $2x^2 - 4x + 5$ find the value of a) $\alpha^2 + \beta^2$ b) $(\alpha - \beta)^2$.

(Ans: a) -1 , b) -6)

Ans: $p(x) = 2x^2 - 4x + 5$

$$\alpha + \beta = \frac{-b}{a} = \frac{4}{2} = 2$$

$$\alpha\beta = \frac{c}{a} = \frac{5}{2}$$

$$\alpha^2 + \beta^2 = (\alpha + \beta)^2 - 2\alpha\beta$$

Substitute then we get, $\alpha^2 + \beta^2 = -1$

$$(\alpha - \beta)^2 = (\alpha + \beta)^2 - 4\alpha\beta$$

Substitute, we get $(\alpha - \beta)^2 = -6$

5. If α, β are the zeros of the polynomial $x^2 + 8x + 6$ form a Quadratic polynomial

whose zeros are a) $\frac{1}{\alpha}$ and $\frac{1}{\beta}$ b) $1 + \frac{\beta}{\alpha}$, $1 + \frac{\alpha}{\beta}$.

(Ans: $x^2 + \frac{4}{3}x + \frac{1}{6}$, $x^2 - \frac{32}{3}x + \frac{32}{3}$)

Ans: $p(x) = x^2 + 8x + 6$
 $\alpha + \beta = -8$ and $\alpha\beta = 6$

a) Let two zeros are $\frac{1}{\alpha}$ and $\frac{1}{\beta}$

$$\text{Sum} = \frac{1}{\alpha} + \frac{1}{\beta} = \frac{\alpha + \beta}{\alpha\beta} = \frac{-8}{6} = \frac{-4}{3}$$

$$\text{Product} = \frac{1}{\alpha} \times \frac{1}{\beta} = \frac{1}{\alpha\beta} = \frac{1}{6}$$

Required Q.P is

$$x^2 + \frac{4}{3}x + \frac{1}{6}$$

b) Let two Zeros are $1 + \frac{\beta}{\alpha}$ and $1 + \frac{\alpha}{\beta}$

$$\text{sum} = 1 + \frac{\beta}{\alpha} + 1 + \frac{\alpha}{\beta}$$

$$= 2 + \frac{\alpha}{\beta} + \frac{\beta}{\alpha}$$

$$= 2 + \frac{\alpha^2 + \beta^2}{\alpha\beta}$$

$$= 2 + \frac{(\alpha + \beta)^2 - 2\alpha\beta}{\alpha\beta} \text{ after solving this problem,}$$

$$\text{We get} = \frac{32}{3}$$

$$\text{Product} = \left(1 + \frac{\beta}{\alpha}\right)\left(1 + \frac{\alpha}{\beta}\right)$$

$$= 1 + \frac{\alpha}{\beta} + \frac{\beta}{\alpha} + 1$$

$$= 2 + \frac{\alpha^2 + \beta^2}{\alpha\beta}$$

Substitute this sum,

We get = $\frac{32}{3}$

Required Q.P. is $x^2 - \frac{32}{3}x + \frac{32}{3}$

6. On dividing the polynomial $4x^4 - 5x^3 - 39x^2 - 46x - 2$ by the polynomial $g(x)$ the quotient is $x^2 - 3x - 5$ and the remainder is $-5x + 8$. Find the polynomial $g(x)$.
(Ans: $4x^2 + 7x + 2$)

Ans: $p(x) = g(x)q(x) + r(x)$

$$g(x) = \frac{p(x) - r(x)}{q(x)}$$

let $p(x) = 4x^4 - 5x^3 - 39x^2 - 46x - 2$

$q(x) = x^2 - 3x - 5$ and $r(x) = -5x + 8$

now $p(x) - r(x) = 4x^4 - 5x^3 - 39x^2 - 41x - 10$

when $\frac{p(x) - r(x)}{q(x)} = 4x^2 + 7x + 2$

$\therefore g(x) = 4x^2 + 7x + 2$

7. If the squared difference of the zeros of the quadratic polynomial $x^2 + px + 45$ is equal to 144, find the value of p . (Ans: ± 18).

Ans: Let two zeros are α and β where $\alpha > \beta$

According given condition

$$(\alpha - \beta)^2 = 144$$

Let $p(x) = x^2 + px + 45$

$$\alpha + \beta = \frac{-b}{a} = \frac{-p}{1} = -p$$

$$\alpha\beta = \frac{c}{a} = \frac{45}{1} = 45$$

now $(\alpha - \beta)^2 = 144$

$$(\alpha + \beta)^2 - 4\alpha\beta = 144$$

$$(-p)^2 - 4(45) = 144$$

Solving this we get $p = \pm 18$

8. If α, β are the zeros of a Quadratic polynomial such that $\alpha + \beta = 24$, $\alpha - \beta = 8$. Find a Quadratic polynomial having α and β as its zeros. (Ans: $k(x^2 - 24x + 128)$)

Ans: $\alpha + \beta = 24$

$\alpha - \beta = 8$

$2\alpha = 32$

$$\alpha = \frac{32}{2} = 16, \therefore \alpha = 16$$

Work the same way to $\alpha + \beta = 24$

$$\text{So, } \beta = 8$$

Q.P is $x^2 - (\text{sum})x + \text{product}$
 $= x^2 - (16+8)x + 16 \times 8$
 Solve this,
 it is $k(x^2 - 24x + 128)$

9. If α & β are the zeroes of the polynomial $2x^2 - 4x + 5$, then find the value of
 a. $\alpha^2 + \beta^2$ b. $1/\alpha + 1/\beta$ c. $(\alpha - \beta)^2$ d. $1/\alpha^2 + 1/\beta^2$ e. $\alpha^3 + \beta^3$

$$(\text{Ans: } -1, \frac{4}{5}, -6, \frac{-4}{25}, -7)$$

Ans: Let $p(x) = 2x^2 - 4x + 5$

$$\alpha + \beta = \frac{-b}{a} = \frac{4}{2} = 2$$

$$\alpha\beta = \frac{c}{a} = \frac{5}{2}$$

a) $\alpha^2 + \beta^2 = (\alpha + \beta)^2 - 2\alpha\beta$

Substitute to get $\alpha^2 + \beta^2 = -1$

b) $\frac{1}{\alpha} + \frac{1}{\beta} = \frac{\alpha + \beta}{\alpha\beta}$

substitute, then we get $= \frac{1}{\alpha} + \frac{1}{\beta} = \frac{4}{5}$

b) $(\alpha - \beta)^2 = (\alpha + \beta)^2 - 4\alpha\beta$

Therefore we get, $(\alpha - \beta)^2 = -6$

d) $\frac{1}{\alpha^2} + \frac{1}{\beta^2} = \frac{\alpha^2 + \beta^2}{\alpha\beta^2} = \frac{-1}{\left(\frac{5}{2}\right)^2}$

$$\therefore \frac{1}{\alpha^2} + \frac{1}{\beta^2} = \frac{-4}{25}$$

e) $\alpha^3 + \beta^3 = (\alpha + \beta)(\alpha^2 + \beta^2 - \alpha\beta)$

Substitute this,

to get, $\alpha^3 + \beta^3 = -7$

10. Obtain all the zeros of the polynomial $p(x) = 3x^4 - 15x^3 + 17x^2 + 5x - 6$ if two zeroes are $-1/\sqrt{3}$ and $1/\sqrt{3}$. (Ans:3,2)
11. Give examples of polynomials $p(x)$, $g(x)$, $q(x)$ and $r(x)$ which satisfy the division algorithm.
 a. $\deg p(x) = \deg q(x)$ b. $\deg q(x) = \deg r(x)$ c. $\deg q(x) = 0$.
12. If the ratios of the polynomial $ax^3 + 3bx^2 + 3cx + d$ are in AP, Prove that $2b^3 - 3abc + a^2d = 0$

Ans: Let $p(x) = ax^3 + 3bx^2 + 3cx + d$ and α, β, r are their three Zeros

but zero are in AP

let $\alpha = m - n$, $\beta = m$, $r = m + n$

$$\text{sum} = \alpha + \beta + r = \frac{-b}{a}$$

$$\text{substitute this sum, to get } m = \frac{-b}{a}$$

$$\text{Now taking two zeros as sum } \alpha\beta + \beta r + \alpha r = \frac{c}{a}$$

$$(m-n)m + m(m+n) + (m+n)(m-n) = \frac{3c}{a}$$

Solve this problem, then we get

$$\frac{3b^2 - 3ac}{a^2} = n^2$$

$$\text{Product } \alpha\beta r = \frac{d}{a}$$

$$(m-n)m(m+n) = \frac{-d}{a}$$

$$(m^2 - n^2)m = \frac{-d}{a}$$

$$\left[\left(\frac{-b}{a} \right)^2 - \left(\frac{3b^2 - 3ac}{a^2} \right) \right] \left(\frac{-b}{a} \right) = \frac{-d}{a}$$

Simplifying we get

$$2b^3 - 3abc + a^2d = 0$$

13. Find the number of zeros of the polynomial from the graph given.

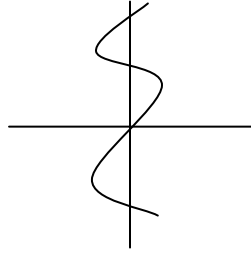

(Ans:1)

14. If one zero of the polynomial $3x^2 - 8x + 2k + 1$ is seven times the other, find the zeros and the value of k (Ans $k = 2/3$)

Self Practice

14. If $(n-k)$ is a factor of the polynomials $x^2 + px + q$ & $x^2 + mx + n$. Prove that

$$k = n + \frac{n - q}{m - p}$$

Ans : since $(n - k)$ is a factor of $x^2 + px + q$

$$\therefore (n - k)^2 + p(n - k) + q = 0$$

$$\text{And } (n - k)^2 + m(n - k) + n = 0$$

Solve this problem by yourself,

$$\therefore k = n + \frac{n - q}{m - p}$$

SELF PRACTICE

16. If $2, \frac{1}{2}$ are the zeros of $px^2 + 5x + r$, prove that $p = r$.

17. If m, n are zeroes of $ax^2 - 5x + c$, find the value of a and c if $m + n = m \cdot n = 10$

(Ans: $a = 1/2, c = 5$)

18. What must be subtracted from $8x^4 + 14x^3 - 2x^2 + 7x - 8$ so that the resulting polynomial is exactly divisible by $4x^2 + 3x - 2$. (Ans: $14x - 10$)

19. What must be added to the polynomial $p(x) = x^4 + 2x^3 - 2x^2 + x - 1$ so that the resulting polynomial is exactly divisible by $x^2 + 2x - 3$. (Ans: $x - 2$)

PAIR OF LINEAR EQUATIONS IN TWO VARIABLES

Like the crest of a peacock so is mathematics at the head of all knowledge.

1. At a certain time in a deer park, the number of heads and the number of legs of deer and human visitors were counted and it was found there were 39 heads & 132 legs. Find the number of deer and human visitors in the park.
(Ans:27,12)

Ans: Let the no. of deers be x
And no. of humans be y

ASQ :

$$x + y = 39 \quad \text{---- (1)}$$

$$4x + 2y = 132 \quad \text{----- (2)}$$

Multiply (1) and (2)

On solving, we get ...

$$x = 27 \quad \text{and} \quad y = 12$$

∴ No. of deers = 27 and No. of humans = 12

2. Solve for x , y

$$\text{a. } \frac{x + y - 8}{2} = \frac{x + 2y - 14}{3} = \frac{3x + y - 12}{11} \quad (\text{Ans: } x=2, y=6)$$

$$\text{Ans: } \frac{x + y - 8}{2} = \frac{x + 2y - 14}{3} = \frac{3x + y - 12}{11}$$

$$\frac{x + y - 8}{2} = \frac{x + 2y - 14}{3}$$

On solving, we will get...y= 6

$$\frac{x + y - 8}{2} = \frac{x - 2}{2} = \frac{x + 2y - 14}{3}$$

On solving , we will get....

$$x = 2$$

b. $7(y + 3) - 2(x + 2) = 14, 4(y - 2) + 3(x - 3) = 2$

Ans: $7(y + 3) - 2(x + 2) = 14$ ----- (1)

$4(y - 2) + 3(x - 3) = 2$ -----(2)

From (1) $7y + 21 - 2x - 4 = 14$

On solving, we will get....

$2x - 7y - 3 = 0$ ----- (3)

From (2) $4y - 8 + 3x - 9 = 2$

On solving, we will get....

$3x + 4y - 19 = 0$ ----- (4)

$2x - 7y - 3$

$3x + 4y - 19$

Substitute this, to get $y = 1$ and $x = 5$

$\therefore x = 5$ and $y = 1$

c. $(a+2b)x + (2a- b)y = 2, (a - 2b)x + (2a +b)y = 3$

(Ans: $\frac{5b - 2a}{10ab}, \frac{a + 10b}{10ab}$)

Ans:

$2ax + 4ay = y$

, we get $4bx - 2by = -1$

$2ax + 4ay = 5 \quad 4bx - 2by = -1$

Solve this, to get $y = \frac{10b + a}{10ab}$

Similarly, we can solve for x

$$\text{d. } \frac{x}{a} + \frac{y}{b} = a + b, \frac{x}{a^2} + \frac{y}{b^2} = 2 ; a \neq 0, b \neq 0$$

(Ans: $x=a^2, y=B^2$)

Ans: $\frac{x}{a} + \frac{y}{b} = a + b$

$$\frac{x}{a^2} + \frac{y}{b^2} = 2$$

$$\frac{xb + ya}{ab} = a + b$$

$$\frac{xb^2 + ya^2}{a^2b^2} = 2$$

On solving , we get ... $x = a^2$ and $y = b^2$

e. $2^x + 3^y = 17, 2^{x+2} - 3^{y+1} = 5$

Ans: $2^x + 3^y = 17, 2^{x+2} - 3^{y+1} = 5$

Let 2^x be a and 3^y be b

$$2^x + 3^y = 17$$

$$a + b = 17 \text{ ----(1)}$$

$$2^{x+2} - 3^{y+1} = 5$$

$$4a - 3b = 5 \text{ -----(2)}$$

on solving , we get..... $a = 8$

from (1)

$$a + b = - 17$$

$$\therefore b = 9, a = 8$$

$$\Rightarrow x = 3, y = 2$$

f. **If** $\frac{4x-3y}{7x-6y} = \frac{4}{13}$, **Find** $\frac{x}{y}$ **Ans:** $\frac{4x-3y}{7x-6y} = \frac{4}{13}$

On dividing by y , we get $\frac{x}{y} = \frac{5}{8}$

g. **41x + 53y = 135, 53x + 41y = 147**

Ans: $41x + 53y = 135, 53x + 41y = 147$

Add the two equations :

Solve it, to get ... $x + y = 3$ -----(1)

Subtract :

Solve it , to get, $x - y = 1$ -----(2)

From (1) and (2)

$$x + y = 3$$

$$x - y = 1$$

on solving , we get ... $x = 2$ and $y = 1$

3. Find the value of p and q for which the system of equations represent coincident lines
 $2x + 3y = 7, (p+q+1)x + (p+2q+2)y = 4(p+q)+1$

Ans: $a_1 = 2, b_1 = 3, c_1 = 7$

$$a_2 = p + q + 1, b_2 = p + 2q + 2, c_2 = (p + q) + 1$$

For the following system of equation the condition must be

$$\frac{a_1}{a_2} = \frac{b_1}{b_2} = \frac{c_1}{c_2}$$

$$\Rightarrow \frac{2}{p+q+1} = \frac{3}{p+q+2} = \frac{7}{4(p+q)+1}$$

$$\Rightarrow \frac{2}{p+q+1} = \frac{7}{4(p+q)+1}$$

$$7p + 14q + 14 = 12p + 12q + 3$$

$$= 5p - 2q - 11 = 0 \text{ -----(2)}$$

$$p + q - 5 = 0$$

$$5p - 2q - 11 = 0$$

From (1) and (2)

$$5p + 5q - 25 = 0$$

$$5p - 2q - 11 = 0$$

Solve it, to get $q = 2$

Substitute value of q in equation (1)

$$p + q - 5 = 0$$

On solving we get, $p = 3$ and $q = 2$

4. Students are made to stand in rows. If one student is extra in a row there would be 2 rows less. If one student is less in a row there would be 3 rows more. Find the number of students in the class.

Ans: No. of rows be y

Let the number of students be x

Number of students in the class will be $= xy$

One student extra, 2 rows less

$$(x + 1)(y - 2) = xy$$

$$xy - 2x + y - 2 = xy$$

$$-(-2x + y - 2) = 0$$

$$+2x - y = -2 \text{ ----- (1)}$$

One student less, three more rows

$$(x - 1)(y + 3) = xy$$

$$xy + 3x - y - 3 = xy$$

$$3x - y = 3 \text{ -----(2)}$$

From (1) & (2)

$$2x - y = -2 \text{ X } 3$$

$$3x - y = 3 \text{ X } -2$$

Solve it, to get ... $y = 12$ and $x = 5$

\therefore Number of student $= xy$

$$= 12 \text{ X } 5$$

$$= 60 \text{ students}$$

5. The larger of two supplementary angles exceeds the smaller by 18° , find them. (Ans: $99^\circ, 81^\circ$)

Ans: $x + y = 180^\circ$
 $x - y = 18^\circ$

 $2x = 198$

$$x = 198 / 2 = x = 99^\circ$$

$$x + y = 180^\circ$$

$$y = 180 - 99$$

$$y = 81^\circ$$

6. A train covered a certain distance at a uniform speed. If the train would have been 6km/hr faster, it would have taken 4hours less than the scheduled time. And if the train were slower by 6km/hr, it would have taken 6 hours more than the scheduled time. Find the distance of the journey.

Ans: Let the speed of the train by x km/hr
 And the time taken by it by y
 Now distance traveled by it is $x \times y = xy$

APQ:

I--- $(x + 6)(y - 4) = xy$
 $4x - 6y = -24$
 $\Rightarrow 2x - 3y = -12$ -----(1)

II--- $(x - 6)(y + 6) = xy$
 $6x - 6y = 36$
 $\Rightarrow x - y = 6$ -----(2)

Solving for x and y we get $y = 24$, $x = 30$

$$\text{So the distance} = 30 \times 24$$

$$= 720 \text{ km}$$

7. A chemist has one solution which is 50% acid and a second which is 25% acid. How much of each should be mixed to make 10 litres of 40% acid solution. (Ans:6L,4L)

Ans: Let 50 % acids in the solution be x
 Let 25 % of other solution be y

$$\text{Total Volume in the mixture} = x + y$$

A.P.Q:
 $x + y = 10$ -----(1)

A.P.Q: $\frac{50}{100}x + \frac{25}{100}y = \frac{40}{100} \times 10$
 $2x + y = 16$ -----(2)

So $x = 6$ & $y = 4$

8. The length of the sides of a triangle are $2x + \frac{y}{2}$, $\frac{5x}{3} + y + \frac{1}{2}$ and $\frac{2}{3}x + 2y + \frac{5}{2}$. If the triangle is equilateral. Find its perimeter.

Ans: $2x + \frac{y}{2}$
 $= \frac{4x + y}{2}$ -----(1)

$= \frac{10x + 6y + 3}{6}$ -----(2)

$\frac{2}{3}x + 2y + \frac{5}{2}$

$= \frac{4x + 12y + 15}{6}$ -----(3)

APQ:
 $\frac{4x + y}{2} = \frac{10x + 6y + 3}{6} = \frac{4x + 12y + 15}{6}$

$24x + 6y = 20x + 12y + 6$
 $2x - 3y = 3$ -----(4)

$\frac{4x + y}{2} = \frac{4x + 12y + 15}{6}$

$24x + 6y = 8x + 24y + 30$

Solve it,

To get $8x - 9y = 15$ -----(5)

Solve it ,

To get $x = 3$

Substitute value of x in (4)

$2x - 3y = 3$

Solve it ,

To get $y = 1$

So the values of $x = 3$ and $y = 1$

$$2x + \frac{y}{2} = 6.5 \text{ cm}$$

$$\text{Perimeter} = 6.5 \text{ cm} + 6.5 \text{ cm} + 6.5 \text{ cm}$$

$$\text{Perimeter} = 19.5 \text{ cm}$$

\therefore the perimeter of the triangle is 19.5 cm

8. In an election contested between A and B, A obtained votes equal to twice the no. of persons on the electoral roll who did not cast their votes & this later number was equal to twice his majority over B. If there were 18000 persons on the electoral roll. How many voted for B.

Ans: Let x and y be the no. of votes for A & B respectively.

The no. of persons who did not vote = $(18000 - x - y)$

APQ:

$$x = 2(18000 - x - y)$$
$$\Rightarrow 3x + 2y = 36000 \text{ -----(1)}$$

&

$$(18000 - x - y) = (2)(x - y)$$

$$\Rightarrow 3x - y = 18000 \text{ -----(2)}$$

On solving we get, $y = 6000$ and $x = 8000$

Vote for B = 6000

9. When 6 boys were admitted & 6 girls left the percentage of boys increased from 60% to 75%. Find the original no. of boys and girls in the class.

Ans: Let the no. of Boys be x

Girls be y

$$\text{Total} = x + y$$

APQ:

$$\frac{x}{x+y} = \frac{60}{100} \text{ -----(1)}$$

$$\frac{x+6}{(x+6)(y-6)} = \frac{75}{100}$$

On solving we get,

$$x = 24 \text{ and } y = 16.$$

10. When the son will be as old as the father today their ages will add up to 126 years. When the father was old as the son is today, their ages add upto 38 years. Find their present ages.

Ans: let the son's present age be x

Father's age be y

Difference in age (y - x)

Of this difference is added to the present age of son, then son will be as old as the father now and at that time, the father's age will be [y + (y - x)]

APQ:

$$[x + (y - x)] + [y (y - x)] = 126$$

$$[y + (x - y)] + [x + (x - y)] = 38$$

Solving we get the value of x and y

11. A cyclist, after riding a certain distance, stopped for half an hour to repair his bicycle, after which he completes the whole journey of 30km at half speed in 5 hours. If the breakdown had occurred 10km farther off, he would have done the whole journey in 4 hours. Find where the breakdown occurred and his original speed.

(Ans: 10km, 10km/hr)

Ans: Let x be the place where breakdown occurred

y be the original speed

$$\frac{x}{y} + \frac{30-x}{\frac{y}{2}} = 5$$

$$\frac{x+10}{y} + \frac{30-(x+10)}{\frac{y}{2}} = 4$$

$$\frac{x}{y} + \frac{60 - 2x}{y} = 5$$

On solving, we get, $x = 10$ km and $y = 10$ km/h

12. The population of the village is 5000. If in a year, the number of males were to increase by 5% and that of a female by 3% annually, the population would grow to 5202 at the end of the year. Find the number of males and females in the village.

Let the number of Males be x and females be y

Ans: $x + y = 5000$

$$x + \frac{5}{100}x + y + \frac{3y}{100} = 5202 \quad \dots 1$$

$$\Rightarrow 5x + 3y = 20200 \quad \dots 2$$

On solving 1 & 2 we get $x = 2600$ $y = 2400$ -

No. of males = 2600

No. of females = 2400

UNIT-4

QUADRATIC EQUATIONS

For the things of this world cannot be made known without a knowledge of mathematics.

1. Solve by factorization

a. $4x^2 - 4a^2x + (a^4 - b^4) = 0$

Ans: $4x^2 - 4a^2x + (a^4 - b^4) = 0$
 $4x^2 - [2(a^2 + b^2) + 2(a^2 - b^2)]x + (a^2 - b^2)(a^2 + b^2) = 0$
 $\Rightarrow 2x[2x - (a^2 + b^2)] - (a^2 - b^2)[2x - (a^2 + b^2)] = 0$
 $\Rightarrow x = \frac{a^2 + b^2}{2} \quad x = \frac{a^2 - b^2}{2}$

b. $x^2 + \left(\frac{a}{a+b} + \frac{a+b}{a}\right)x + 1 = 0$

Ans: $x^2 + \left(\frac{a}{a+b} + \frac{a+b}{a}\right)x + 1$
 $\Rightarrow x^2 + \left(\frac{a}{a+b}x + \frac{a+b}{a}x + \frac{a}{a+b} \cdot \frac{a+b}{a}\right)$
 $\Rightarrow x \left[x + \frac{a}{a+b}\right] + \frac{a+b}{a} \left[x + \frac{a}{a+b}\right] = 0$
 $\Rightarrow x = \frac{-a}{a+b} \quad x = \frac{(-a+b)}{a} \quad a+b \neq 0$

c. $\frac{1}{a+b+x} = \frac{1}{a} + \frac{1}{b} + \frac{1}{x} \quad a + b \neq 0$

Ans: $\frac{1}{a+b+x} = \frac{1}{a} + \frac{1}{b} + \frac{1}{x}$
 $\Rightarrow \frac{1}{a+b+x} - \frac{1}{x} = \frac{1}{a} + \frac{1}{b}$
 $\Rightarrow \frac{x - (a+b+x)}{x(a+b+x)} = \frac{a+b}{ab}$
 $\Rightarrow (a+b)\{x(a+b+x)+ab\} = 0$
 $\Rightarrow x(a+b+x)+ab = 0$
 $\Rightarrow x^2 + ax + bx + ab = 0$
 $\Rightarrow (x+a)(x+b) = 0$
 $\Rightarrow x = -a \quad x = -b$

$$d. (x-3)(x-4) = \frac{34}{33^2}$$

$$\text{Ans : } (x-3)(x-4) = \frac{34}{33^2}$$

$$\Rightarrow x^2 - 7x + 12 = \frac{34}{33^2}$$

$$x^2 - 7x + \frac{13034}{33^2} = 0$$

$$x^2 - 7x + \frac{98}{33}x - \frac{133}{33} = 0$$

$$x^2 - \frac{231}{33}x + \frac{98}{33}x - \frac{133}{33} = 0$$

$$x^2 - \left(\frac{98}{33} + \frac{133}{33}\right)x + \frac{98}{33}x - \frac{133}{33} = 0$$

$$\Rightarrow \left(x - \frac{98}{33}\right)\left(x - \frac{133}{33}\right) = 0$$

$$\Rightarrow x = \frac{98}{33} \text{ or } x = \frac{133}{33}$$

$$e. \quad x = \frac{1}{2 - \frac{1}{2 - \frac{1}{2-x}}} \quad x \neq 2$$

$$\text{Ans: } x = \frac{2}{2 - \frac{1}{2 - \frac{1}{2-x}}} \quad x \neq 2$$

$$x = \frac{1}{2 - \frac{1}{2 - \frac{1}{2-x}}}$$

$$x = \frac{1}{2 - \frac{1}{2 - \frac{(2-x)}{4-2x-1}}}}$$

$$x = \frac{1}{2 - \frac{2-x}{3-2x}}$$

$$\Rightarrow x = \frac{3-2x}{2(3-2x) - (2-x)}$$

$$\Rightarrow x = \frac{3-2x}{4-3x}$$

$$\Rightarrow 4x - 3x^2 = 3 - 2x$$

$$\Rightarrow 3x^2 - 6x + 3 = 0$$

$$\Rightarrow (x-1)^2 = 0$$

$$x = 1, 1.$$

2. By the method of completion of squares show that the equation $4x^2 + 3x + 5 = 0$ has no real roots.

Ans: $4x^2 + 3x + 5 = 0$

$$\Rightarrow x^2 + \frac{3}{4}x + \frac{5}{4} = 0$$

$$\Rightarrow x^2 + \frac{3}{4}x + \left(\frac{3}{8}\right)^2 = \frac{-5}{4} + \frac{9}{64}$$

$$\Rightarrow \left(x + \frac{3}{8}\right)^2 = \frac{-71}{64}$$

$$\Rightarrow \left(x + \frac{3}{8}\right)^2 = \frac{-71}{64}$$

$$\Rightarrow x + \frac{3}{8} = \sqrt{\frac{-71}{64}} \text{ not a real no.}$$

Hence QE has no real roots.

3. The sum of areas of two squares is 468m^2 If the difference of their perimeters is 24cm, find the sides of the two squares.

Ans: Let the side of the larger square be x .
Let the side of the smaller square be y .

$$\text{APQ } x^2 + y^2 = 468$$

$$\text{Cond. II } \quad 4x - 4y = 24$$

$$\Rightarrow x - y = 6$$

$$\begin{aligned} \Rightarrow x &= 6 + y \\ x^2 + y^2 &= 468 \\ \Rightarrow (6+y)^2 + y^2 &= 468 \\ &\text{on solving we get } y = 12 \\ \Rightarrow x &= (12+6) = 18 \text{ m} \\ \therefore \text{ sides are } &18\text{m \& } 12\text{m.} \end{aligned}$$

4. A dealer sells a toy for Rs.24 and gains as much percent as the cost price of the toy. Find the cost price of the toy.

Ans: Let the C.P be x
 \therefore Gain = $x\%$
 \Rightarrow Gain = $x \cdot \frac{x}{100}$
S.P = C.P + Gain
SP = 24
 $\Rightarrow x + \frac{x^2}{100} = 24$
On solving $x=20$ or -120 (rej)
 \therefore C.P of toy = Rs.20

5. A fox and an eagle lived at the top of a cliff of height 6m, whose base was at a distance of 10m from a point A on the ground. The fox descends the cliff and went straight to the point A. The eagle flew vertically up to a height x metres and then flew in a straight line to a point A, the distance traveled by each being the same. Find the value of x .

Ans: Distance traveled by the fox = distance traveled by the eagle
 $(6+x)^2 + (10)^2 = (16-x)^2$
on solving we get
 $x = 2.72\text{m.}$

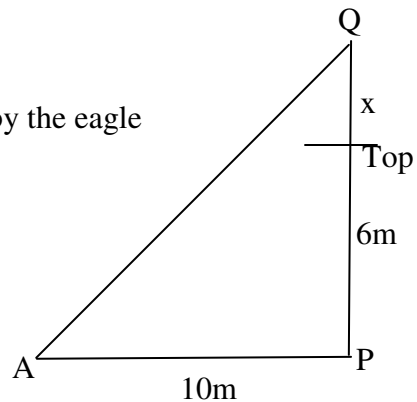

6. A lotus is 2m above the water in a pond. Due to wind the lotus slides on the side and only the stem completely submerges in the water at a distance of 10m from the original position. Find the depth of water in the pond.

Ans: $(x+2)^2 = x^2 + 10^2$
 $x^2 + 4x + 4 = x^2 + 100$
 $\Rightarrow 4x + 4 = 100$
 $\Rightarrow x = 24$
 Depth of the pond = 24m

7 Solve $x = \sqrt{6 + \sqrt{6 + \sqrt{6}}}$

Ans: $x = \sqrt{6 + \sqrt{6 + \sqrt{6}}}$
 $\Rightarrow x = \sqrt{6 + x}$
 $\Rightarrow x^2 = 6 + x$
 $\Rightarrow x^2 - x - 6 = 0$
 $\Rightarrow (x - 3)(x + 2) = 0$
 $\Rightarrow x = 3$

8. The hypotenuse of a right triangle is 20m. If the difference between the length of the other sides is 4m. Find the sides.

Ans: APQ
 $x^2 + y^2 = 20^2$
 $x^2 + y^2 = 400$
 also $x - y = 4$
 $\Rightarrow x = 4 + y$
 $(4 + y)^2 + y^2 = 400$
 $\Rightarrow 2y^2 + 8y - 384 = 0$
 $\Rightarrow (y + 16)(y - 12) = 0$
 $\Rightarrow y = 12 \quad y = -16 \text{ (N.P)}$
 \therefore sides are 12cm & 16cm

9. The positive value of k for which $x^2 + Kx + 64 = 0$ & $x^2 - 8x + k = 0$ will have real roots .

Ans: $x^2 + Kx + 64 = 0$
 $\Rightarrow b^2 - 4ac \geq 0$
 $K^2 - 256 \geq 0$
 $K \geq 16 \text{ or } K \leq -16$ (1)
 $x^2 - 8x + K = 0$
 $64 - 4K \geq 0$

$$\begin{aligned} \Rightarrow 4K &\leq 64 \\ K &\leq 16 \\ \text{From (1) \& (2) } K &= 16 \end{aligned} \quad \dots\dots\dots(2)$$

10. A teacher on attempting to arrange the students for mass drill in the form of a solid square found that 24 students were left over. When he increased the size of the square by one student he found he was short of 25 students. Find the number of students.

Ans: Let the side of the square be x .
 No. of students = $x^2 + 24$
 New side = $x + 1$
 No. of students = $(x + 1)^2 - 25$
 APQ $\Rightarrow x^2 + 24 = (x + 1)^2 - 25$
 $\Rightarrow x^2 + 24 = x^2 + 2x + 1 - 25$
 $\Rightarrow 2x = 48$
 $\Rightarrow x = 24$
 \therefore side of square = 24
 No. of students = $576 + 24$
 $= 600$

11. A pole has to be erected at a point on the boundary of a circular park of diameter 13m in such a way that the differences of its distances from two diametrically opposite fixed gates A & B on the boundary in 7m. Is it possible to do so? If answer is yes at what distances from the two gates should the pole be erected.

Ans: $AB = 13$ m
 $BP = x$
 $\Rightarrow AP - BP = 7$
 $\Rightarrow AP = x + 7$
 APQ
 $\Rightarrow (13)^2 = (x + 7)^2 + x^2$
 $\Rightarrow x^2 + 7x - 60 = 0$
 $(x + 12)(x - 5) = 0$
 $\Rightarrow x = -12$ N.P
 $x = 5$

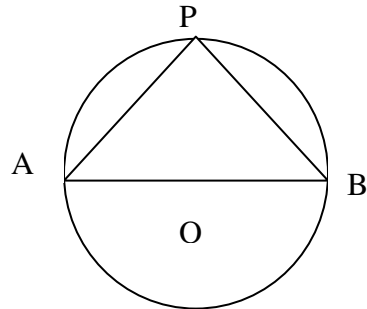

\therefore Pole has to be erected at a distance of 5m from gate B & 12m from gate A.

12. If the roots of the equation $(a-b)x^2 + (b-c)x + (c - a) = 0$ are equal. Prove that $2a=b+c$.

Ans: $(a-b)x^2 + (b-c)x + (c - a) = 0$
 T.P $2a = b + c$
 $B^2 - 4AC = 0$
 $(b-c)^2 - [4(a-b)(c - a)] = 0$
 $b^2 - 2bc + c^2 - [4(ac - a^2 - bc + ab)] = 0$

$$\begin{aligned} \Rightarrow b^2 - 2bc + c^2 - 4ac + 4a^2 + 4bc - 4ab &= 0 \\ \Rightarrow b^2 + 2bc + c^2 + 4a^2 - 4ac - 4ab &= 0 \\ \Rightarrow (b + c - 2a)^2 &= 0 \\ \Rightarrow b + c &= 2a \end{aligned}$$

13. X and Y are centers of circles of radius 9cm and 2cm and $XY = 17$ cm. Z is the centre of a circle of radius 4 cm, which touches the above circles externally. Given that $\angle XZY = 90^\circ$, write an equation in r and solve it for r.

Ans: Let r be the radius of the third circle

$$XY = 17\text{cm} \Rightarrow XZ = 9 + r \quad YZ = 2 + r$$

APQ

$$\begin{aligned} (r + 9)^2 + (r + 2)^2 &= (17)^2 \\ \Rightarrow r^2 + 18r + 81 + r^2 + 4r + 4 &= 289 \\ \Rightarrow r^2 + 22r - 104 &= 0 \\ (r + 17)(r - 6) &= 0 \\ \Rightarrow r &= -17 \text{ (N.P)} \\ r &= 6 \text{ cm} \\ \therefore \text{radius} &= 6\text{cm.} \end{aligned}$$

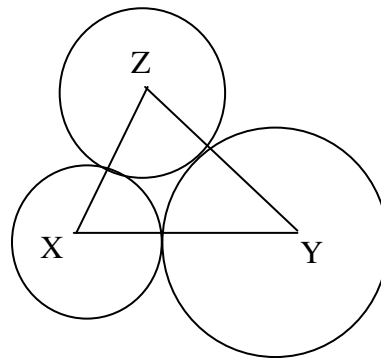

ARITHMETIC PROGRESSIONS

One of the endlessly alluring aspects of mathematics is that its thorniest paradoxes have a way of blooming into beautiful theories

1. The fourth term of an AP is 0. Prove that its 25th term is triple its 11th term.

Ans: $a_4 = 0$
 $\Rightarrow a + 3d = 0$
 T.P $a_{25} = 3(a_{11})$
 $\Rightarrow a + 24d = 3(a + 10d)$
 $\Rightarrow a + 24d = 3a + 30d$
 RHS sub $a = -3d$
 $-3d + 24d = 21d$
 LHS $3a + 30d$
 $-9d + 30d = 21d$
 LHS = RHS
 Hence proved

2. Find the 20th term from the end of the AP 3, 8, 13.....253.

Ans: 3, 8, 13 253
 Last term = 253
 a_{20} from end
 $= l - (n-1)d$
 $253 - (20-1)5$
 $253 - 95$
 $= 158$

3. If the pth, qth & rth term of an AP is x, y and z respectively, show that $x(q-r) + y(r-p) + z(p-q) = 0$

Ans: pth term $\Rightarrow x = A + (p-1)D$
 qth term $\Rightarrow y = A + (q-1)D$
 rth term $\Rightarrow z = A + (r-1)D$
 T.P $x(q-r) + y(r-p) + z(p-q) = 0$
 $= \{A+(p-1)D\}(q-r) + \{A + (q-1)D\}(r-p)$
 $\quad + \{A+(r-1)D\}(p-q)$
 $A \{(q-r) + (r-p) + (p-q)\} + D \{(p-1)(q-r)$
 $\quad + (q-1)(r-p) + (r-1)(p-q)\}$
 $\Rightarrow A.0 + D\{p(q-r) + q(r-p) + r(p-q)$
 $\quad - (q-r) - (r-p) - (p-q)\}$
 $= A.0 + D.0 = 0.$

Hence proved

4. Find the sum of first 40 positive integers divisible by 6 also find the sum of first 20 positive integers divisible by 5 or 6.

Ans: No's which are divisible by 6 are

6, 12 240.

$$S_{40} = \frac{40}{2}[6 + 240]$$

$$= 20 \times 246$$

$$= 4920$$

No's div by 5 or 6

30, 60 600

$$\frac{20}{2}[30 + 600] = 10 \times 630$$

$$= 6300$$

5. A man arranges to pay a debt of Rs.3600 in 40 monthly instalments which are in a AP. When 30 instalments are paid he dies leaving one third of the debt unpaid. Find the value of the first instalment.

Ans: Let the value of I instalment be x $S_{40} = 3600$.

$$\Rightarrow \frac{40}{2}[2a + 39d] = 3600$$

$$\Rightarrow 2a + 39d = 180 \quad - \quad 1$$

$$S_{30} = \frac{30}{2}[2a + 29d] = 2400$$

$$\Rightarrow 30a + 435d = 2400$$

$$\Rightarrow 2a + 29d = 160 \quad - \quad 2$$

Solve 1 & 2 to get

$$d = 2 \quad a = 51.$$

\therefore I instalment = Rs.51.

6. Find the sum of all 3 digit numbers which leave remainder 3 when divided by 5.

Ans: 103, 108.....998

$$a + (n-1)d = 998$$

$$\Rightarrow 103 + (n-1)5 = 998$$

$$\Rightarrow n = 180$$

$$S_{180} = \frac{180}{2}[103 + 998]$$

$$= 90 \times 1101$$

$$S_{180} = 99090$$

7. Find the value of x if $2x + 1$, $x^2 + x + 1$, $3x^2 - 3x + 3$ are consecutive terms of an AP.

Ans:

$$a_2 - a_1 = a_3 - a_2$$

$$\Rightarrow x^2 + x + 1 - 2x - 1 = 3x^2 - 3x + 3 - x^2 - x - 1$$

$$x^2 - x = 2x^2 - 4x + 2$$

$$\Rightarrow x^2 - 3x + 2 = 0$$

$$\Rightarrow (x - 1)(x - 2) = 0$$

$$\Rightarrow x = 1 \text{ or } x = 2$$

8. Raghav buys a shop for Rs.1,20,000. He pays half the balance of the amount in cash and agrees to pay the balance in 12 annual instalments of Rs.5000 each. If the rate of interest is 12% and he pays with the instalment the interest due for the unpaid amount. Find the total cost of the shop.

Ans: Balance = Rs.60,000 in 12 instalment of Rs.5000 each.

Amount of I instalment = $5000 + \frac{12}{100} 60,000$

II instalment = $5000 + (\text{Interest on unpaid amount})$
 $= 5000 + 6600 \left[\frac{12}{100} \times 55000 \right]$
 $= 11600$

III instalment = $5000 + (\text{Interest on unpaid amount of Rs.50,000})$

\therefore AP is 12200, 11600, 11000

$D = 600$

Cost of shop = 60000 + [sum of 12 instalment]

$$= 60,000 + \frac{12}{2} [24,400 - 6600]$$

$$= 1,66,800$$

9. Prove that $a_{m+n} + a_{m-n} = 2a_m$

Ans: $a_{m+n} = a_1 + (m+n-1)d$

$$a_{m-n} = a_1 + (m-n-1)d$$

$$a_m = a_1 + (m-1)d$$

Add 1 & 2

$$a_{m+n} + a_{m-n} = a_1 + (m+n-1)d + a_1 + (m-n-1)d$$

$$= 2a_1 + (m+n+m-n-1-1)d$$

$$= 2a_1 + 2(m-1)d$$

$$\begin{aligned}
&= 2[a_1 + (m-1)d] \\
&= 2[a_1 + (m-1)d] \\
&= 2a_m \quad \text{Hence proved.}
\end{aligned}$$

10. If the roots of the equation $(b-c)x^2 + (c-a)x + (a-b) = 0$ are equal show that a, b, c are in AP.

Ans: Refer sum No.12 of Q.E.

If $(b-c)x^2 + (c-a)x + (a-b)$ have equal root.

$$B^2 - 4AC = 0.$$

Proceed as in sum No.13 of Q.E to get $c + a = 2b$

$$\Rightarrow b - a = c - b$$

$\Rightarrow a, b, c$ are in AP

11. Balls are arranged in rows to form an equilateral triangle .The first row consists of one ball, the second two balls and so on. If 669 more balls are added, then all the balls can be arranged in the shape of a square and each of its sides then contains 8 balls less than each side of the triangle. find the initial number of balls.

Ans: Let their be n balls in each side of the triangle

$$\therefore \text{No. of ball (in } \Delta) = 1 + 2 + 3 + \dots = \frac{n(n+1)}{2}$$

No. of balls in each side square = $n-8$

No. of balls in square = $(n-8)^2$

$$\text{APQ } \frac{n(n+1)}{2} + 660 = (n-8)^2$$

On solving

$$n^2 + n + 1320 = 2(n^2 - 16n + 64)$$

$$n^2 - 33n - 1210 = 0$$

$$\Rightarrow (n-55)(n+22) = 0$$

$$n = -22 \text{ (N.P)}$$

$$n = 55$$

$$\therefore \text{No. of balls} = \frac{n(n+1)}{2} = \frac{55 \times 56}{2}$$

$$= 1540$$

12. Find the sum of $(1 - \frac{1}{n}) + (1 - \frac{2}{n}) + (1 - \frac{3}{n}) + \dots$ upto n terms.

Ans: $(1 - \frac{1}{n}) + (1 - \frac{2}{n}) -$ upto n terms

$$\Rightarrow [1+1+\dots+n \text{ terms}] - [\frac{1}{n} + \frac{2}{n} + \dots + n \text{ terms}]$$

$$n - [S_n \text{ up to } n \text{ terms}]$$

$$\begin{aligned}
S_n &= \frac{n}{2} [2a + (n-1)d] \quad \left(d = \frac{1}{n}, a = \frac{1}{n}\right) \\
&= \frac{n}{2} \left[\frac{2}{n} + (n-1)\frac{1}{n} \right] \\
&= \frac{n+1}{2} \quad (\text{on simplifying})
\end{aligned}$$

$$\begin{aligned}
n - \frac{n+1}{2} &= \\
&= \frac{n-1}{2} \text{ Ans}
\end{aligned}$$

13. If the following terms form a AP. Find the common difference & write the next 3 terms $3, 3 + \sqrt{2}, 3 + 2\sqrt{2}, 3 + 3\sqrt{2}, \dots$

Ans: $d = \sqrt{2}$ next three terms $3 + 4\sqrt{2}, 3 + 5\sqrt{2}, 3 + 6\sqrt{2}, \dots$

14. Find the sum of $a+b, a-b, a-3b, \dots$ to 22 terms.

Ans: $a + b, a - b, a - 3b$, up to 22 terms
 $d = a - b - a - b = -2b$
 $S_{22} = \frac{22}{2} [2(a+b) + 21(-2b)]$
 $11[2a + 2b - 42b]$
 $= 22a - 440b$ Ans.

15. Write the next two terms $\sqrt{12}, \sqrt{27}, \sqrt{48}, \sqrt{75}, \dots$

Ans: next two terms $\sqrt{108}, \sqrt{147}$ AP is $2\sqrt{3}, 3\sqrt{3}, 4\sqrt{3}, 5\sqrt{3}, 6\sqrt{3}, 7\sqrt{3}, \dots$

16. If the p^{th} term of an AP is q and the q^{th} term is p . P.T its n^{th} term is $(p+q-n)$.

Ans: APQ
 $a_p = q$
 $a_q = p$
 $a_n = ?$
 $a + (p-1)d = q$
 $a + (q-1)d = p$
 $d[p - q] = q - p$ Sub $d = -1$ to get $\Rightarrow = -1 \Rightarrow a = q + p - 1$
 $a_n = a + (n - 1)d$
 $= a + (n - 1)d$
 $= (q + p - 1) + (n - 1) - 1$
 $a_n = (q + p - n)$

17. If $\frac{1}{x+2}, \frac{1}{x+3}, \frac{1}{x+5}$ are in AP find x.

Ans: $\frac{1}{x+2}, \frac{1}{x+3}, \frac{1}{x+5}$ are in AP find x.

$$\frac{1}{x+3} - \frac{1}{x+2} = \frac{1}{x+5} - \frac{1}{x+3}$$

$$\Rightarrow \frac{1}{x^2 + 5x + 6} = \frac{2}{x^2 + 8x + 15}$$

On solving we get $x = 1$

18. Find the middle term of the AP 1, 8, 15....505.

Ans: Middle terms

$$a + (n-1)d = 505$$

$$a + (n-1)7 = 505$$

$$n - 1 = \frac{504}{7}$$

$$n = 73$$

\therefore 37th term is middle term

$$a_{37} = a + 36d$$

$$= 1 + 36(7)$$

$$= 1 + 252$$

$$= 253$$

19. Find the common difference of an AP whose first term is 100 and sum of whose first 6 terms is 5 times the sum of next 6 terms.

Ans: $a = 100$

$$\text{APQ } a_1 + a_2 + \dots + a_6 = 5(a_7 + \dots + a_{12})$$

$$6\left(\frac{a_1 + a_6}{2}\right) = 5 \times 6\left(\frac{a_7 + a_{12}}{2}\right)$$

$$\Rightarrow a + a + 5d = 5[a + 6d + a + 11d]$$

$$\Rightarrow 8a + 80d = 0 \quad (a = 100)$$

$$\Rightarrow d = -10.$$

20. Find the sum of all natural no. between 101 & 304 which are divisible by 3 or 5. Find their sum.

Ans: No let 101 and 304, which are divisible by 3.

102, 105.....303 (68 terms)

No. which are divisible by 5 are 105, 110.....300 (40 terms)

No. which are divisible by 15 (3 & 5) 105, 120..... (14 terms)
 \therefore There are 94 terms between 101 & 304 divisible by 3 or 5. $(68 + 40 - 14)$
 $\therefore S_{68} + S_{40} - S_{14}$
 $= 19035$

21. The ratio of the sum of first n terms of two AP's is $7n+1:4n+27$. Find the ratio of their 11th terms .

Ans: Let a_1, a_2, \dots and d_1, d_2 be the I terms and Cd's of two AP's.

$$\frac{S_n \text{ of one AP}}{S_n \text{ of II AP}} = \frac{7n+1}{4n+27}$$

$$\frac{\frac{n}{2}[2a_1 + (n-1)d_1]}{\frac{n}{2}[2a_2 + (n-1)d_2]} = \frac{7n+1}{4n+27}$$

$$\Rightarrow \frac{2a_1 + (n-1)d_1}{2a_2 + (n-1)d_2} = \frac{7n+1}{4n+27}$$

We have sub. $n = 21$.

$$\frac{2a_1 + 20d_1}{2a_2 + 20d_2} = \frac{7 \times 21 + 1}{4(21) + 27}$$

$$\Rightarrow \frac{a_1 + 10d_1}{a_2 + 10d_2} = \frac{148}{111}$$

$$= \frac{4}{3}$$

\therefore ratio of their 11th terms = 4 : 3.

22. If there are $(2n+1)$ terms in an AP, prove that the ratio of the sum of odd terms and the sum of even terms is $(n+1):n$

Ans: Let a, d be the I term & Cd of the AP.

$$\therefore a_k = a + (k-1)d$$

$s_1 =$ sum to odd terms

$$s_1 = a_1 + a_3 + \dots + a_{2n+1}$$

$$s_1 = \frac{n+1}{2}[a_1 + a_{2n+1}]$$

$$= \frac{n+1}{2}[2a_1 + 2nd]$$

$$s_1 = (n+1)(a + nd)$$

$s_2 =$ sum to even terms

$$s_2 = a_2 + a_4 + \dots + a_{2n}$$

$$\begin{aligned}
s_2 &= \frac{n}{2} [a_2 + a_{2n}] \\
&= \frac{n}{2} [a + d + a + (2n - 1)d] \\
&= n [a + nd] \\
\therefore s_1 : s_2 &= \frac{(n+1)(a+nd)}{n(a+nd)} \\
&= \frac{n+1}{n}
\end{aligned}$$

23. Find the sum of all natural numbers amongst first one thousand numbers which are neither divisible 2 or by 5

Ans: Sum of all natural numbers in first 1000 integers which are not divisible by 2 i.e. sum of odd integers.

$$1 + 3 + 5 + \dots + 999$$

$$n = 500$$

$$S_{500} = \frac{500}{2} [1 + 999]$$

$$= 2,50,000$$

No's which are divisible by 5

$$5 + 15 + 25 \dots + 995$$

$$n = 100$$

$$S_n = \frac{100}{2} [5 + 995]$$

$$= 50 \times 1000 = 50000$$

$$\therefore \text{Required sum} = 250000 - 50,000$$

$$= 200000$$

TRIGONOMETRY

"The mathematician is fascinated with the marvelous beauty of the forms he constructs, and in their beauty he finds everlasting truth."

1. If $x\cos\theta - y\sin\theta = a$, $x\sin\theta + y\cos\theta = b$, prove that $x^2 + y^2 = a^2 + b^2$.

Ans: $x\cos\theta - y\sin\theta = a$
 $x\sin\theta + y\cos\theta = b$
 Squaring and adding
 $x^2 + y^2 = a^2 + b^2$.

2. Prove that $\sec^2\theta + \operatorname{cosec}^2\theta$ can never be less than 2.

Ans: S.T $\sec^2\theta + \operatorname{cosec}^2\theta$ can never be less than 2.
 If possible let it be less than 2.
 $1 + \tan^2\theta + 1 + \cot^2\theta < 2$
 $\Rightarrow 2 + \tan^2\theta + \cot^2\theta < 2$
 $\Rightarrow (\tan\theta + \cot\theta)^2 < 2$
 Which is not possible.

3. If $\sin\phi = \frac{1}{2}$, show that $3\cos\phi - 4\cos^3\phi = 0$.

Ans: $\sin\phi = \frac{1}{2}$
 $\Rightarrow \phi = 30^\circ$
 Substituting in place of $\phi = 30^\circ$. We get 0.

4. If $7\sin^2\phi + 3\cos^2\phi = 4$, show that $\tan\phi = \frac{1}{\sqrt{3}}$.

Ans: If $7\sin^2\phi + 3\cos^2\phi = 4$ S.T. $\tan\phi = \frac{1}{\sqrt{3}}$
 $7\sin^2\phi + 3\cos^2\phi = 4(\sin^2\phi + \cos^2\phi)$
 $\Rightarrow 3\sin^2\phi = \cos^2\phi$
 $\Rightarrow \frac{\sin^2\phi}{\cos^2\phi} = \frac{1}{3}$

$$\Rightarrow \tan^2 \phi = \frac{1}{3}$$

$$\tan \phi = \frac{1}{\sqrt{3}}$$

5. If $\cos \phi + \sin \phi = \sqrt{2} \cos \phi$, prove that $\cos \phi - \sin \phi = \sqrt{2} \sin \phi$.

Ans: $\cos \phi + \sin \phi = \sqrt{2} \cos \phi$
 $\Rightarrow (\cos \phi + \sin \phi)^2 = 2 \cos^2 \phi$
 $\Rightarrow \cos^2 \phi + \sin^2 \phi + 2 \cos \phi \sin \phi = 2 \cos^2 \phi$
 $\Rightarrow \cos^2 \phi - 2 \cos \phi \sin \phi + \sin^2 \phi = 2 \sin^2 \phi$ $\left[\begin{array}{l} \therefore 2 \sin^2 \phi = 2 - 2 \cos^2 \phi \\ 1 - \cos^2 \phi = \sin^2 \phi \text{ \& } 1 - \sin^2 \phi = \cos^2 \phi \end{array} \right]$
 $\cos^2 \phi$
or $\cos \phi - \sin \phi = \sqrt{2} \sin \phi$.

6. If $\tan A + \sin A = m$ and $\tan A - \sin A = n$, show that $m^2 - n^2 = 4\sqrt{mn}$

Ans: $\tan A + \sin A = m$ $\tan A - \sin A = n$.
 $m^2 - n^2 = 4\sqrt{mn}$.
 $m^2 - n^2 = (\tan A + \sin A)^2 - (\tan A - \sin A)^2$
 $= 4 \tan A \sin A$
RHS $4\sqrt{mn} = 4 \sqrt{(\tan A + \sin A)(\tan A - \sin A)}$
 $= 4 \sqrt{\tan^2 A - \sin^2 A}$
 $= 4 \sqrt{\frac{\sin^2 A - \sin^2 A \cos^2 A}{\cos^2 A}}$
 $= 4 \sqrt{\frac{\sin^4 A}{\cos^2 A}}$
 $= 4 \frac{\sin^2 A}{\cos^2 A} = 4 \tan A \sin A$
 $\therefore m^2 - n^2 = 4\sqrt{mn}$

7. If $\sec A = x + \frac{1}{4x}$, prove that $\sec A + \tan A = 2x$ or $\frac{1}{2x}$.

Ans: $\text{Sec}\varphi = x + \frac{1}{4x}$

$$\Rightarrow \text{Sec}^2\varphi = \left(x + \frac{1}{4x}\right)^2 \quad (\text{Sec}^2\varphi = 1 + \text{Tan}^2\varphi)$$

$$\text{Tan}^2\varphi = \left(x + \frac{1}{4x}\right)^2 - 1$$

$$\text{Tan}^2\varphi = \left(x - \frac{1}{4x}\right)^2$$

$$\text{Tan}\varphi = \pm x - \frac{1}{4x}$$

$$\begin{aligned} \text{Sec}\varphi + \text{Tan}\varphi &= x + \frac{1}{4x} \pm x - \frac{1}{4x} \\ &= 2x \text{ or } \frac{1}{2x} \end{aligned}$$

8. If A, B are acute angles and $\sin A = \cos B$, then find the value of A+B.

Ans: $A + B = 90^\circ$

9. a) Solve for φ , if $\tan 5\varphi = 1$.

Ans: $\text{Tan } 5\varphi = 1 \Rightarrow \varphi = \frac{45}{5} \Rightarrow \varphi = 9^\circ$.

b) Solve for φ if $\frac{\sin\varphi}{1 + \cos\varphi} + \frac{1 + \cos\varphi}{\sin\varphi} = 4$.

Ans: $\frac{\sin\varphi}{1 + \cos\varphi} + \frac{1 + \cos\varphi}{\sin\varphi} = 4$

$$\frac{\sin^2\varphi + 1(\cos\varphi)^2}{\sin\varphi(1 + \cos\varphi)} = 4$$

$$\frac{\sin^2\varphi + 1 + \cos^2\varphi + 2\cos\varphi}{\sin\varphi + \sin\varphi\cos\varphi} = 4$$

$$\frac{2 + 2\cos\varphi}{\sin\varphi(1 + \cos\varphi)} = 4$$

$$\Rightarrow \frac{2 + (1 + \cos \varphi)}{\sin \varphi (1 + \cos \varphi)} = 4$$

$$\Rightarrow \frac{2}{\sin \varphi} = 4$$

$$\Rightarrow \sin \varphi = \frac{1}{2}$$

$$\Rightarrow \begin{aligned} \sin \varphi &= \sin 30^\circ \\ \varphi &= 30^\circ \end{aligned}$$

10. If $\frac{\cos \alpha}{\cos \beta} = m$ and $\frac{\cos \alpha}{\sin \beta} = n$, show that $(m^2 + n^2) \cos^2 \beta = n^2$

Ans: $\frac{\cos \alpha}{\cos \beta} = m$ $\frac{\cos \alpha}{\sin \beta} = n$

$$\Rightarrow m^2 = \frac{\cos^2 \alpha}{\cos^2 \beta} \quad n^2 = \frac{\cos^2 \alpha}{\sin^2 \beta}$$

$$\text{LHS} = (m^2 + n^2) \cos^2 \beta$$

$$\begin{aligned} & \left[\frac{\cos^2 \alpha}{\cos^2 \beta} + \frac{\cos^2 \alpha}{\sin^2 \beta} \right] \cos^2 \beta \\ &= \cos^2 \alpha \left(\frac{1}{\cos^2 \beta \sin^2 \beta} \right) \cos^2 \beta \\ &= \frac{\cos^2 \alpha}{\sin^2 \beta} = n^2 \\ &\Rightarrow (m^2 + n^2) \cos^2 \beta = n^2 \end{aligned}$$

11. If $7 \operatorname{cosec} \varphi - 3 \cot \varphi = 7$, prove that $7 \cot \varphi - 3 \operatorname{cosec} \varphi = 3$.

Ans: $7 \operatorname{Cosec} \varphi - 2 \cot \varphi = 7$
P.T $7 \cot \varphi - 3 \operatorname{Cosec} \varphi = 3$
 $7 \operatorname{Cosec} \varphi - 3 \cot \varphi = 7$
 $\Rightarrow 7 \operatorname{Cosec} \varphi - 7 = 3 \cot \varphi$
 $\Rightarrow 7(\operatorname{Cosec} \varphi - 1) = 3 \cot \varphi$

$$\begin{aligned} &\Rightarrow 7(\operatorname{Cosec}\phi - 1)(\operatorname{Cosec}\phi + 1) = 3\cot\phi(\operatorname{Cosec}\phi + 1) \\ &\Rightarrow 7(\operatorname{Cosec}^2\phi - 1) = 3\cot\phi(\operatorname{Cosec}\phi + 1) \\ &\Rightarrow 7\cot^2\phi = 3\cot\phi(\operatorname{Cosec}\phi + 1) \\ &\Rightarrow 7\cot\phi = 3(\operatorname{Cosec}\phi + 1) \\ &7\cot\phi - 3\operatorname{Cosec}\phi = 3 \end{aligned}$$

12. $2(\sin^6\phi + \cos^6\phi) - 3(\sin^4\phi + \cos^4\phi) + 1 = 0$

Ans: $(\sin^2\phi)^3 + (\cos^2\phi)^3 - 3(\sin^4\phi + \cos^4\phi) + 1 = 0$
 Consider $(\sin^2\phi)^3 + (\cos^2\phi)^3$
 $\Rightarrow (\sin^2\phi + \cos^2\phi)^3 - 3\sin^2\phi\cos^2\phi(\sin^2\phi + \cos^2\phi)$
 $= 1 - 3\sin^2\phi\cos^2\phi$
 $\sin^4\phi + \cos^4\phi(\sin^2\phi)^2 + (\cos^2\phi)^2$
 $= (\sin^2\phi + \cos^2\phi)^2 - 2\sin^2\phi\cos^2\phi$
 $= 1 - 2\sin^2\phi\cos^2\phi$
 $= 2(\sin^6\phi + \cos^6\phi) - 3(\sin^4\phi + \cos^4\phi) + 1$
 $= 2(1 - 3\sin^2\phi\cos^2\phi) - 3(1 - 2\sin^2\phi\cos^2\phi) + 1$

13. $5(\sin^8 A - \cos^8 A) = (2\sin^2 A - 1)(1 - 2\sin^2 A \cos^2 A)$

Ans: Proceed as in Question No.12

14. If $\tan\theta = \frac{5}{6}$ & $\theta + \phi = 90^\circ$ what is the value of $\cot\phi$.

Ans: $\tan\theta = \frac{5}{6}$ i.e. $\cot\phi = \frac{5}{6}$ Since $\phi + \theta = 90^\circ$.

15. What is the value of $\tan\phi$ in terms of $\sin\phi$.

Ans: $\tan\phi = \frac{\sin\phi}{\cos\phi}$
 $\tan\phi = \frac{\sin\phi}{\sqrt{1 - \sin^2\phi}}$

16. If $\sec\phi + \tan\phi = 4$ find $\sin\phi$, $\cos\phi$

Ans: $\sec\phi + \tan\phi = 4$

$$\frac{1}{\cos\phi} + \frac{\sin\phi}{\cos\phi} = 4$$

$$\frac{1 + \sin\phi}{\cos\phi} = 4$$

$$\Rightarrow \frac{(1 + \sin \phi)^2}{\cos^2 \phi} = 16$$

\Rightarrow apply (C & D)

$$= \frac{(1 + \sin \phi)^2 + \cos^2 \phi}{(1 + \sin \phi)^2 - \cos^2 \phi} = \frac{16 + 1}{16 - 1}$$

$$\Rightarrow \frac{2(1 + \sin \phi)}{2\sin \phi(1 + \sin \phi)} = \frac{17}{15}$$

$$\Rightarrow \frac{1}{\sin \phi} = \frac{17}{15}$$

$$\Rightarrow \sin \phi = \frac{15}{17}$$

$$\cos \phi = \sqrt{1 - \sin^2 \phi}$$

$$\sqrt{1 - \left(\frac{15}{17}\right)^2} = \frac{8}{17}$$

17. $\sec \phi + \tan \phi = p$, prove that $\sin \phi = \frac{p^2 - 1}{p^2 + 1}$

Ans: $\sec \phi + \tan \phi = P$. P.T $\sin \phi = \frac{P^2 - 1}{P^2 + 1}$

Proceed as in Question No.15

18. Prove geometrically the value of $\sin 60^\circ$

Ans: Exercise for practice.

19. If $\frac{1 - \tan \theta}{1 + \tan \theta} = \frac{\sqrt{3} - 1}{\sqrt{3} + 1}$, show that $\frac{\sin \theta}{\cos 2\theta} = 1$

Ans: Exercise for practice.

20. If $2x = \sec \theta$ and $\frac{2}{x} = \tan \theta$, then find the value of $2\left(x^2 - \frac{1}{x^2}\right)$.

(Ans:1)

Ans: Exercise for practice.

HEIGHTS AND DISTANCES

1. If the angle of elevation of cloud from a point 'h' meters above a lake is α and the angle of depression of its reflection in the lake is β , prove that the height of the cloud is .

Ans :

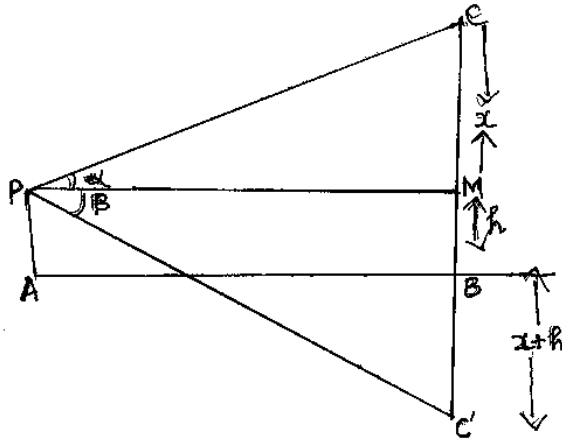

If the angle of elevation of cloud from a point 'n' meters above a lake is α and the angle of depression of its reflection in the lake is β , prove that the height of the

cloud is $h \left(\frac{\tan \beta + \tan \alpha}{\tan \beta - \tan \alpha} \right)$

Let AB be the surface of the lake and

Let p be an point of observation such that AP = h meters. Let c be the position of the cloud and c' be its reflection in the lake. Then $\angle CPM = \alpha$ and $\angle MPC' = \beta$.

Let CM = x.

Then, CB = CM + MB = CM + PA = x + h

In ΔCPM , we have $\tan \alpha = \frac{CM}{PM}$

$$\Rightarrow \tan \alpha = \frac{x}{AB}$$

[$\therefore PM = AB$]

$$\Rightarrow AB = x \cot \alpha \quad \dots\dots\dots 1$$

In $\Delta PMC'$, we have

$$\tan \beta = \frac{C'M}{PM}$$

$$\Rightarrow \tan \beta = \frac{x + 2h}{AB} \quad [\because C'M = C'B + BM = x + h + h]$$

$$\Rightarrow AB = (x + 2h) \cot \beta$$

From 1 & 2

$$x \cot \alpha = (x + 2h) \cot \beta$$

$$x (\cot \alpha - \cot \beta) = 2h \cot \beta \text{ (on equating the values of AB)}$$

$$\Rightarrow x \left(\frac{1}{\tan \alpha} - \frac{1}{\tan \beta} \right) = \frac{2h}{\tan \beta} \Rightarrow x \left(\frac{\tan \beta - \tan \alpha}{\tan \alpha + \tan \beta} \right) = \frac{2h}{\tan \beta}$$

$$\Rightarrow x = \frac{2h \tan \alpha}{\tan \beta - \tan \alpha}$$

Hence, the height CB of the cloud is given by CB is given by $CB = x + h$

$$\Rightarrow CB = \frac{2h \tan \alpha}{\tan \beta - \tan \alpha} + h$$

$$\Rightarrow CB = \frac{2h \tan \alpha + h \tan \beta - h \tan \alpha}{\tan \beta - \tan \alpha} = \frac{h(\tan \alpha + h \tan \beta)}{\tan \beta - \tan \alpha}$$

2. From an aero plane vertically above a straight horizontal road, the angles of depression of two consecutive milestones on opposite sides of the aero plane are observed to be α and β . Show that the height of the aero plane above the road is

$$\frac{\tan \alpha \tan \beta}{\tan \alpha + \tan \beta}$$

Ans:

Let PQ be h

QB be x

Given : AB = 1 mile

QB = x

AQ = (1 - x) mile

in ΔPAQ

$$\tan \alpha = \frac{PQ}{AQ}$$

$$\tan \alpha = \frac{h}{1-x}$$

$$1-x = \frac{h}{\tan \alpha} \quad \dots\dots\dots 1$$

In ΔPQB

$$\tan \beta = \frac{h}{x}$$

$$x = \frac{h}{\tan \beta}$$

Substitute for x in equation (1)

$$1 = \frac{h}{\tan \beta} + \frac{h}{\tan \alpha}$$

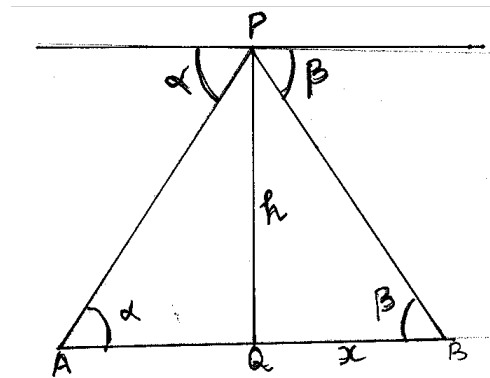

$$1 = h \left\{ \frac{1}{\tan \beta} + \frac{1}{\tan \alpha} \right\}$$

$$\frac{1}{h} = \frac{\tan \beta + \tan \alpha}{\tan \beta \tan \alpha}$$

$$\therefore h = \frac{\tan \alpha \tan \beta}{\tan \alpha + \tan \beta}$$

3. Two stations due south of a tower, which leans towards north are at distances 'a' and 'b' from its foot. If α and β be the elevations of the top of the tower from the situation, prove that its inclination ' θ ' to the horizontal given by

$$\cot \theta = \frac{b \cot \alpha - a \cot \beta}{b - a}$$

Ans: Let AB be the leaning tower and C and D be the given stations. Draw $BL \perp DA$ produced.

Then, $\angle BAL = \theta$, $\angle BCA = \alpha$, $\angle BDC = \beta$ and $DA = b$.

Let $AL = x$ and $BL = h$

In right $\triangle ALB$, we have :

$$\frac{AL}{BL} = \cot \theta \Rightarrow \frac{x}{h} = \cot \theta$$

$$\Rightarrow \frac{x}{h} = \cot \theta \Rightarrow x = h \cot \theta \quad \dots(i)$$

In right $\triangle BCL$, we have :

$$\frac{CL}{BL} = \cot \alpha \Rightarrow a + x = h \cot \alpha$$

$$\Rightarrow a = h (\cot \alpha - \cot \theta)$$

$$\Rightarrow h = \frac{a}{(\cot \alpha - \cot \theta)} \quad \dots(ii)$$

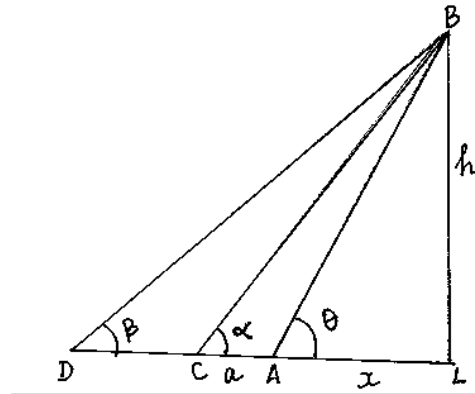

In right $\triangle BDL$, we have :

$$\frac{DL}{BL} = \cot \beta \Rightarrow \frac{DA + AL}{BL} = \cot \beta$$

$$\Rightarrow \frac{b + x}{h} = \cot \beta \Rightarrow b + x = h \cot \beta$$

$$\Rightarrow b = h ((\cot \beta - \cot \theta)) \quad [\text{using (i)}]$$

$$\Rightarrow h = \frac{b}{(\cot \beta - \cot \theta)} \quad \dots(iii)$$

equating the value of h in (ii) and (iii), we get:

$$\frac{a}{(\cot \alpha - \cot \theta)} = \frac{b}{(\cot \beta - \cot \theta)}$$

$$\begin{aligned} \Rightarrow a \cot \beta - a \cot \theta &= b \cot \alpha - b \cot \theta \\ \Rightarrow (b - a) \cot \theta &= b \cot \alpha - a \cot \beta \\ \Rightarrow \cot \theta &= \frac{b \cot \alpha - a \cot \beta}{(b - a)} \end{aligned}$$

4. The angle of elevation of the top of a tower from a point on the same level as the foot of the tower is α . On advancing 'p' meters towards the foot of the tower, the angle of elevation becomes β . show that the height 'h' of the tower is given by $h = \frac{p(\tan \alpha \tan \beta)}{\tan \beta - \tan \alpha}$
5. A boy standing on a horizontal plane finds a bird flying at a distance of 100m from him at an elevation of 30° . A girl standing on the roof of 20 meter high building finds the angle of elevation of the same bird to be 45° . Both the boy and the girl are on opposite sides of the bird. Find the distance of the bird from the girl. (Ans: 42.42m)

Ans: In right ΔACB

$$\begin{aligned} \sin 30 &= \frac{AC}{AB} \\ \frac{1}{2} &= \frac{AC}{100} \\ 2 AC &= 100 \\ AC &= 50\text{m} \\ \Rightarrow AF &= (50 - 20) = 30\text{m} \\ \text{In right } \Delta AFE \\ \sin 45 &= \frac{AF}{AE} \\ \Rightarrow \frac{1}{\sqrt{2}} &= \frac{30}{AE} \\ AE &= 30 \sqrt{2} \\ &= 30 \times 1.414 \\ &= 42.42\text{m} \end{aligned}$$

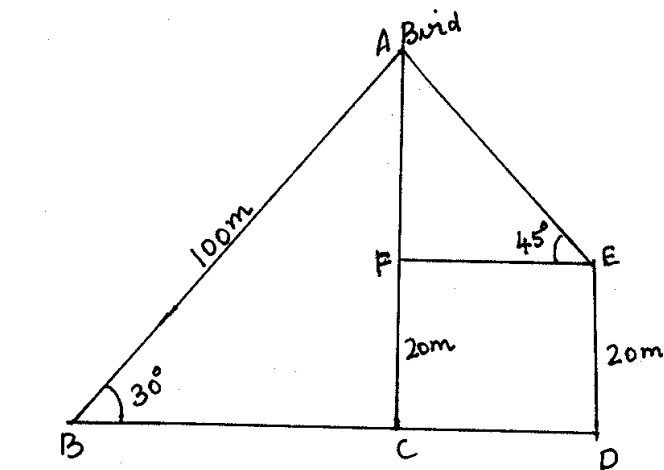

6. From a window x meters high above the ground in a street, the angles of elevation and depression of the top and the foot of the other house on the opposite side of the street are α and β respectively. Show that the height of the opposite house is $x(1 + \tan \alpha \cot \beta)$ Meters.

Ans: Let AB be the house and P be the window
 Let BQ = x \therefore PC = x
 Let AC = a

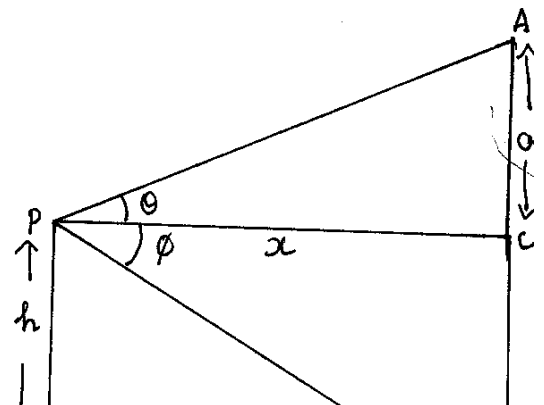

$$\text{In } \Delta PQB, \tan \theta = \frac{PQ}{QB} \text{ or } \tan \theta = \frac{h}{x}$$

$$\therefore x = \frac{h}{\tan \theta} = h \cot \theta$$

$$\text{In } \Delta PAC, \tan \theta = \frac{AC}{PC} \text{ or } \tan \theta = \frac{a}{x}$$

$$\begin{aligned} \therefore a &= x \tan \theta > (h \cot \theta) \tan \theta = h \tan \theta \cot \theta. \\ \therefore \text{the height of the tower} &= AB = AC + BC \\ &= a + h = h \tan \theta \cot \theta + h = h (\tan \theta \cot \theta + 1) \end{aligned}$$

7. Two ships are sailing in the sea on either side of a lighthouse; the angles of depression of two ships as observed from the top of the lighthouse are 60° and 45° respectively. If the distance between the ships is $200\left(\frac{1+\sqrt{3}}{\sqrt{3}}\right)$ meters, find the height of the lighthouse. (Ans:200m)

Ans: In right ΔABC

$$\tan 60 = \frac{h}{BC}$$

$$\sqrt{3} = \frac{h}{BC}$$

$$\Rightarrow h = \sqrt{3} BC$$

In right ΔABD

$$\tan 45 = \frac{h}{BD}$$

$$h = BD$$

$$BC + BD = 200 \left(\frac{1+\sqrt{3}}{\sqrt{3}} \right)$$

$$BC + \sqrt{3} BC = 200 \left(\frac{1+\sqrt{3}}{\sqrt{3}} \right)$$

$$\Rightarrow BC = \frac{200(1+\sqrt{3})}{\sqrt{3}\sqrt{(1+\sqrt{3})}}$$

$$\therefore h = \sqrt{3} BC$$

$$= \sqrt{3} \frac{200}{\sqrt{3}}$$

$$= 200\text{m}$$

$$\therefore \text{height of light house} = 200\text{m}$$

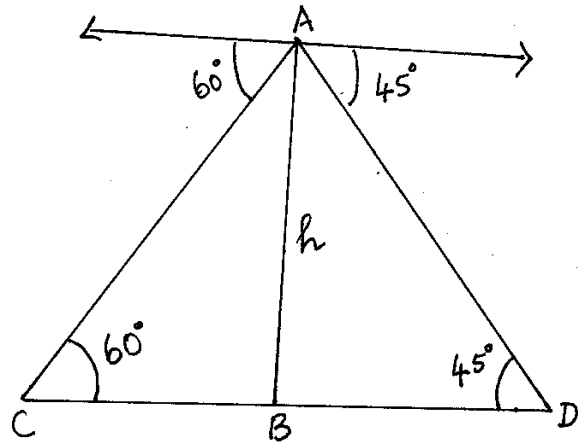

8. A round balloon of radius 'a' subtends an angle θ at the eye of the observer while the angle of elevation of its centre is Φ . Prove that the height of the center of the balloon is $a \sin \theta \operatorname{cosec} \Phi / 2$.

Ans: Let θ be the centre of the balloon of radius 'r' and 'p' the eye of the observer. Let PA, PB be tangents from P to ballong. Then $\angle APB = \theta$.

$$\therefore \angle APO = \angle BPO = \frac{\theta}{2}$$

Let OL be perpendicular from O on the horizontal PX. We are given that the angle of the elevation of the centre of the ballon is ϕ i.e.,

$$\angle OPL = \phi$$

In ΔOAP , we have $\sin \frac{\theta}{2} = \frac{OA}{OP}$

$$\Rightarrow \sin \frac{\theta}{2} = \frac{a}{OP}$$

$$OP = a \operatorname{cosec} \frac{\theta}{2}$$

In ΔOPL , we have $\sin \phi = \frac{OL}{OP}$

$$\Rightarrow OL = OP \sin \phi = a \operatorname{cosec} \frac{\theta}{2} \sin \theta.$$

Hence, the height of the center of the balloon is $a \sin \theta \operatorname{cosec} \Phi / 2$.

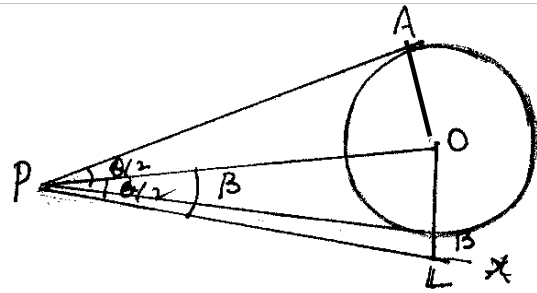

9. The angle of elevation of a jet fighter from a point A on the ground is 60° . After a flight of 15 seconds, the angle of elevation changes to 30° . If the jet is flying at a speed of 720 km/hr, find the constant height at which the jet is flying. (Use $\sqrt{3} = 1.732$) (Ans: 2598m)

Ans: $36 \text{ km / hr} = 10 \text{ m / sec}$
 $720 \text{ km / h} = \frac{10 \times 720}{36}$

Speed = 200 m/s
 Distance of jet from
 AE = speed x time
 = 200 x 15
 = 3000 m

$$\tan 60^\circ = \frac{AC}{BC} \left(\frac{\text{oppositeside}}{\text{adjacentside}} \right)$$

$$\sqrt{3} = \frac{AC}{BC}$$

$$BC \sqrt{3} = AC$$

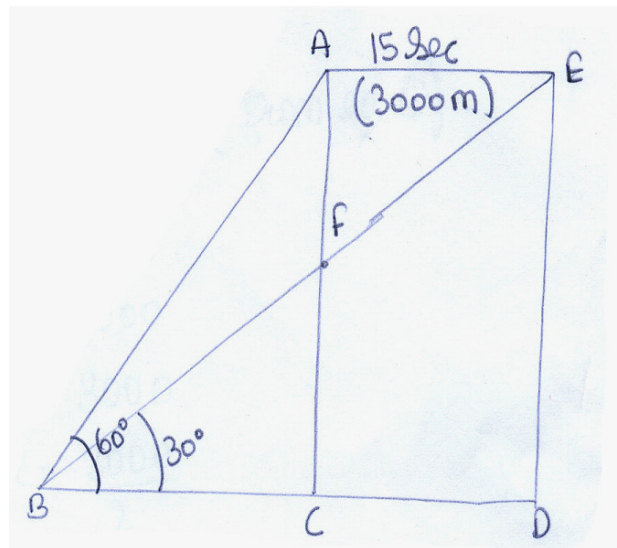

$$\begin{aligned}
& AC = ED \text{ (constant height)} \\
& \therefore BC \sqrt{3} = ED \dots\dots\dots 1 \\
& \tan 30^\circ = \frac{ED}{BC + CD} \left(\frac{\text{opposite side}}{\text{adjacent side}} \right) \\
& \frac{1}{\sqrt{3}} = \frac{ED}{BC + 3000} \\
& \frac{BC + 3000}{\sqrt{3}} = ED \\
& \frac{BC + 3000}{\sqrt{3}} = BC \sqrt{3} \text{ (from equation 1)} \\
& BC + 3000 = 3BC \\
& 3BC - BC = 3000 \\
& 2 BC = 3000 \\
& BC = \frac{3000}{2}
\end{aligned}$$

$$BC = 1500 \text{ m}$$

$$\begin{aligned}
ED &= BC \sqrt{3} \text{ (from equation 1)} \\
&= 1500 \sqrt{3} \\
&= 1500 \times 1.732 \\
ED &= 2598\text{m}
\end{aligned}$$

\therefore The height of the jet fighter is 2598m.

10. A vertical post stands on a horizontal plane. The angle of elevation of the top is 60° and that of a point x metre be the height of the post, then prove that $x = \frac{2h}{3}$.

Self Practice

11. A fire in a building B is reported on telephone to two fire stations P and Q, 10km apart from each other on a straight road. P observes that the fire is at an angle of 60° to the road and Q observes that it is an angle of 45° to the road. Which station should send its team and how much will this team have to travel? (Ans:7.32km)

Self Practice

12. A ladder sets against a wall at an angle α to the horizontal. If the foot is pulled away from the wall through a distance of 'a', so that it slides a distance 'b' down the wall making an angle β with the horizontal. Show that $\frac{\cos \alpha - \cos \beta}{\sin \beta - \sin \alpha} = \frac{a}{b}$.

Ans: Let CB = x m. Length of ladder remains same

13. Two stations due south of a leaning tower which leans towards the north are at distances a and b from its foot. If α , β be the elevations of the top of the tower from these stations, prove that its inclination ϕ is given by $\cot \phi = \frac{b \cot \alpha - a \cot \beta}{b - a}$.

Ans:

Let $AE = x$, $BE = h$

$$\tan \phi = \frac{BE}{AE} = \frac{h}{x}$$

$$x = h \times \frac{1}{\tan \phi}$$

$$x = h \cot \phi \text{ -----1}$$

$$\tan \alpha = \frac{BE}{CE} = \frac{h}{a+x}$$

$$a+x = h \cot \alpha$$

$$x = h \cot \alpha - a \text{ -----2}$$

$$\tan \beta = \frac{BE}{DE} = \frac{h}{b+x}$$

$$b+x = h \cot \beta$$

$$x = h \cot \beta - b \text{ -----3}$$

from 1 and 2

$$h \cot \phi = h \cot \alpha - a$$

$$h (\cot \phi + \cot \alpha) = a$$

$$h = \frac{a}{-\cot \phi + \cot \alpha} \text{ -----4}$$

from 1 and 3

$$h \cot \phi = h \cot \beta - b$$

$$h (\cot \phi - \cot \beta) = b$$

$$h = \frac{b}{-\cot \phi + \cot \beta}$$

from 4 and 5

$$\frac{a}{-\cot \phi + \cot \alpha} = \frac{b}{-\cot \phi + \cot \beta}$$

$$a (\cot \beta - \cot \phi) = b (\cot \alpha - \cot \phi)$$

$$- a \cot \phi + b \cot \phi = b \cot \alpha - a \cot \beta$$

$$(b - a) \cot \phi = b \cot \alpha - a \cot \beta$$

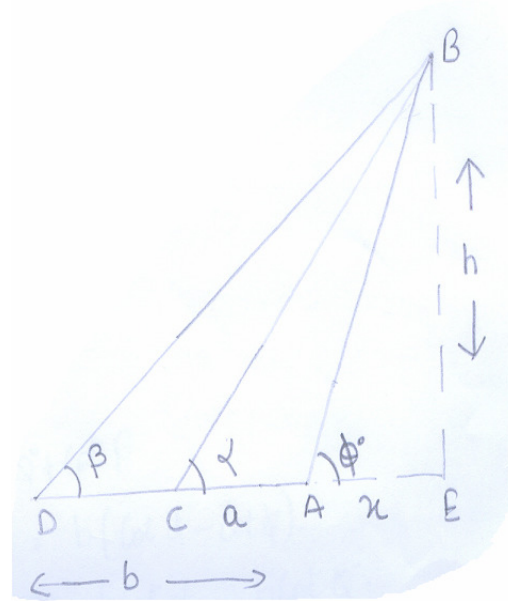

$$\cot \phi = \frac{b \cot \alpha - a \cot \beta}{b - a}$$

14. In Figure, what are the angles of depression from the observing positions O_1 and O_2 of the object at A?

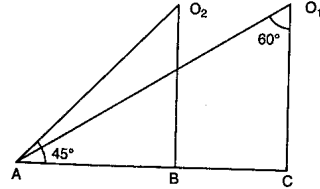

(Ans: $30^\circ, 45^\circ$)

Self Practice

15. The angle of elevation of the top of a tower standing on a horizontal plane from a point A is α . After walking a distance d towards the foot of the tower the angle of elevation is found to be β . Find the height of the tower. (Ans: $\frac{d}{\cot \alpha - \cot \beta}$)

Ans:

Let $BC = x$

$$\tan \beta = \frac{AB}{CB}$$

$$\tan \beta = \frac{h}{x}$$

$$x = \frac{h}{\tan \beta}$$

$$x = h \cot \beta \quad \text{-----(1)}$$

$$\tan \alpha = \frac{AB}{DC + CB}$$

$$\tan \alpha = \frac{h}{d + x}$$

$$d + x = \frac{h}{\tan \alpha} = h \cot \alpha$$

$$x = h \cot \alpha - d \quad \text{-----(2)}$$

from 1 and 2

$$h \cot \beta = h \cot \alpha - d$$

$$h (\cot \alpha - \cot \beta) = d$$

$$h = \frac{d}{\cot \alpha - \cot \beta}$$

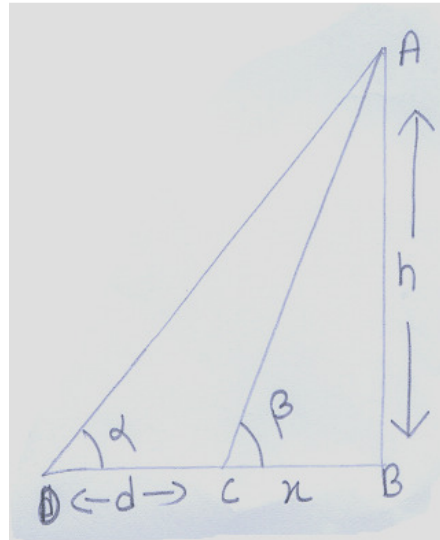

16. A man on a top of a tower observes a truck at an angle of depression α where $\tan\alpha = \frac{1}{\sqrt{5}}$ and sees that it is moving towards the base of the tower. Ten minutes later, the angle of depression of the truck is found to be β where $\tan\beta = \sqrt{5}$, if the truck is moving at a uniform speed, determine how much more time it will take to reach the base of the tower...

$$10 \text{ minutes} = 600 \text{ sec}$$

Ans: Let the speed of the truck be x m/sec $CD = BC - BD$
 In right triangle ABC

$$\tan\alpha = \frac{h}{BC} \quad \tan\alpha = \frac{1}{\sqrt{5}}$$

$$BC = h\sqrt{5} \dots\dots\dots 1$$

In right triangle ABD

$$\tan\beta = \frac{h}{BD}$$

$$h = \sqrt{5}BD$$

$$CD = BC - BD \quad (CD = 600x)$$

$$600x = 5BD - BD$$

$$BD = 150x$$

$$\text{Time taken} = \frac{150x}{x}$$

$$= 150 \text{ seconds}$$

Time taken by the truck to reach the tower is 150 sec.

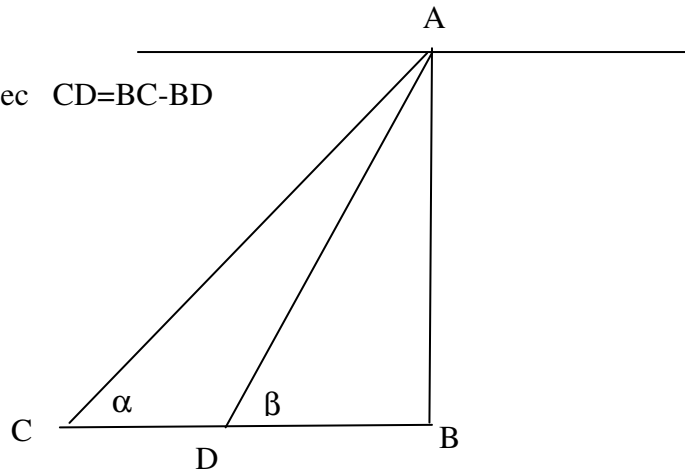

CO-ORDINATE GEOMETRY

Mathematics is the tool specially suited for dealing with abstract concepts of any kind and there is no limit to its power in this field.

1. Find the points on the y axis whose distances from the points (6, 7) and (4,-3) are in the ratio 1:2. [Ans:(0, 9) , (0, $\frac{35}{3}$)]

Ans: Point on y-axis (0, y)
 A(6, 7) B(4, -3) ratio 1:2

$$\frac{6^2 + (7 - y)^2}{4^2 + (-3 - y)^2} = \left(\frac{1}{2}\right)^2$$

On solving we get (0, 9) & (0, $\frac{35}{3}$)

2. Determine the ratio in which the line $2x + y - 4 = 0$ divide the line segment joining the points A (2,-2) and B (3, 7).Also find the coordinates of the point of division.

[Ans:2 : 9 , ($\frac{24}{11}$, $-\frac{4}{11}$)]

Ans : Let the ratio be k:1

Let the co-ordinates of point of division be (x, y)

$$\therefore x = \frac{k(3)+1.2}{k+1} = \frac{3k+2}{k+1}$$

$$y = \frac{k(7)-1.2}{k+1} = \frac{7k-2}{k+1}$$

(x, y) lies on the line $2x + y - 4 = 0$.

$$\therefore 2\left(\frac{3k+2}{k+1}\right) + \left(\frac{7k-2}{k+1}\right) - 4 = 0$$

$$2(3k+2) + (7k-2) - 4(k+1) = 0$$

$$6k + 4 + 7k - 2 - 4k - 4 = 0$$

$$9k - 2 = 0 \quad k = \frac{2}{9}$$

Ratio is 2:9

$$\therefore x = \frac{3x \frac{2}{9} + 2}{\frac{2}{9} + 1} = \frac{\frac{2}{3} + 2}{\frac{11}{9}} = \frac{\frac{2+6}{3}}{\frac{11}{9}} = \frac{8}{3} \times \frac{9}{11} = \frac{24}{11}$$

$$y = \frac{7\left(\frac{2}{9}\right) - 2}{\frac{2}{9} + 1} = \frac{\frac{14-18}{9}}{\frac{11}{9}} = \frac{-4}{9} \times \frac{9}{11} = \frac{-4}{11}$$

$$\therefore (x, y) = \left(\frac{24}{11}, \frac{-4}{11}\right)$$

3. Find the third vertex of a triangle if its two vertices are (-1, 4) and (5, 2) and mid point of one side is (0, 3).
(Ans: (-5, 4) or (1, 2))

Ans : Let the third vertex be (x, y)
If (0,3) is mid point of BC then

$$\frac{x+5}{2} = 0 \quad (\text{or}) \quad x = -5$$

$$\frac{y+2}{2} = 3 \quad y = 4. \quad (-5, 4)$$

If (0,3) is mid point of AC then

$$\frac{x-1}{2} = 0 \quad x = 1 \quad \frac{y+4}{2} = 3 \quad y + 4 = 6 \quad y = 2 \quad (1, 2)$$

\therefore (-5, 4) or (1, 2) are possible answers.

4. If the vertices of a triangle are (1, k), (4, -3), (-9, 7) and its area is 15 sq units, find the value(s) of k..
[Ans: -3, $\frac{21}{13}$]

Ans: A(1, k) B(4, -3) C(-9, 7)

$$\text{Area of } \Delta ABC = \frac{1}{2} [x_1(y_2 - y_3) + x_2(y_3 - y_1) + x_3(y_1 - y_2)]$$

$$= \frac{1}{2} [1(-3-7) + 4(7-k) + (-9)(k+3)] = 15$$

$$-10 + 28 - 4k - 9k - 27 = 30$$

$$-9 - 13k = 30 \quad \Rightarrow \quad k = -3$$

$$|-9 - 13k| = 30$$

$$9 + 13k = 30$$

$$k = \frac{21}{13}$$

$$k = -3, \frac{21}{13}$$

5. The centre of a circle is $(2x - 1, 3x + 1)$. Find x if the circle passes through $(-3, -1)$ and the length of the diameter is 20 units. [Ans: $x = 2, -\frac{46}{13}$]

Ans : $D = 20$ $R = 10$
 $(2x - 1 + 3)^2 + (3x + 1 + 1)^2 = 10^2$
 $(2x + 2)^2 + (3x + 2)^2 = 100$
 $4x^2 + 8x + 4 + 9x^2 + 12x + 4 = 100$
 $13x^2 + 20x + 8 = 100$
 $13x^2 + 20x - 92 = 0$
 $13x^2 + 46x - 26x - 92 = 0$
 $(13x + 46) - 2(13x + 46) = 0$
 $x = 2, \frac{-46}{13}$

6. If A & B are $(-2, -2)$ and $(2, -4)$ respectively, find the co ordinates of P such that

$AP = \frac{3}{7} AB$ and P lies on the line segment AB. [Ans: $(-\frac{2}{7}, -\frac{20}{7})$]

Ans : $AP = \frac{3}{7} AB$
 $\frac{AP}{AB} = \frac{3}{7}$ (i.e) $\frac{AP}{PB} = \frac{3}{4}$
 $AB = AP + PB$
 $AP : PB = 3:4$
 Let $P(x, y)$
 $x = \frac{3(2) + 4(-2)}{7} = \frac{6 - 8}{7} = \frac{-2}{7}$
 $y = \frac{3(-4) + 4(-2)}{7} = \frac{-12 - 8}{7} = \frac{-20}{7}$
 $(x, y) = (\frac{-2}{7}, \frac{-20}{7})$

7. Show that the points $(3, 0)$, $(4, 5)$, $(-1, 4)$ and $(-2, -1)$ taken in order are the vertices of a rhombus. Also find the area of the rhombus. (Ans: 24 sq units)

Ans : Let AC be d_1 & BD be d_2
 $\text{Area} = \frac{1}{2} d_1 d_2$
 $d_1 = \sqrt{(3+1)^2 + (0-4)^2} = \sqrt{4^2 + 4^2} = \sqrt{32} = 4\sqrt{2}$
 $d_2 = \sqrt{(-2-4)^2 + (-1-5)^2} = \sqrt{36 + 36} = \sqrt{72} = 6\sqrt{2}$

$$\text{Area} = \frac{1}{2} d_1 d_2 = \frac{1}{2} \times 4 \times 6 \times 2 = 24 \text{sq units.}$$

8. If A, B and P are the points (-4, 3), (0, -2) and (α, β) respectively and P is equidistant from A and B, show that $8\alpha - 10\beta + 21 = 0$.

Ans : $AP = PB \Rightarrow AP^2 = PB^2$
 $(\alpha + 4)^2 + (\beta - 3)^2 = \alpha^2 + (\beta + 2)^2$
 $\alpha^2 + 8\alpha + 16 + \beta^2 - 6\beta + 9 = \alpha^2 + \beta^2 + 4\beta + 4$
 $8\alpha - 6\beta - 4\beta + 25 - 4 = 0$
 $8\alpha - 10\beta + 21 = 0$

9. If the points (5, 4) and (x, y) are equidistant from the point (4, 5), prove that $x^2 + y^2 - 8x - 10y + 39 = 0$.

Ans : $AP = PB$
 $AP^2 = PB^2$
 $(5 - 4)^2 + (4 - 5)^2 = (x - 4)^2 + (y - 5)^2$
 $1 + 1 = x^2 - 8x + 16 + y^2 - 10y + 25$
 $x^2 + y^2 - 8x - 10y + 41 - 2 = 0$
 $x^2 + y^2 - 8x - 10y + 39 = 0$

10. If two vertices of an equilateral triangle are (0, 0) and (3, 0), find the third vertex.

$$\left[\text{Ans: } \frac{3}{2}, \frac{3\sqrt{3}}{2} \text{ or } \frac{3}{2}, -\frac{3\sqrt{3}}{2} \right]$$

Ans: $OA = OB = AB$
 $OA^2 = OB^2 = AB^2$
 $OA^2 = (3-0)^2 + 0 = 9$
 $OB^2 = x^2 + y^2$
 $AB^2 = (x-3)^2 + y^2 = x^2 + y^2 - 6x + 9$
 $OA^2 = OB^2 = AB^2$
 $OA^2 = OB^2 \ \& \ OB^2 = AB^2$
 $9 = x^2 + y^2 \Rightarrow y^2 = 9 - x^2$
 $x^2 + y^2 - 6x + 9 = 9$

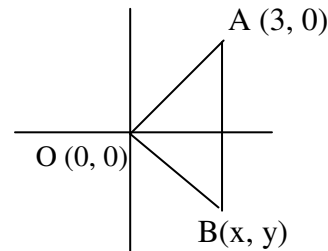

$$x^2 + 9 - x^2 - 6x + 9 = 9$$

$$6x = 9 \quad x = \frac{3}{2}$$

$$y^2 = 9 - \left(\frac{3}{2}\right)^2 = 9 - \frac{9}{4} = \frac{36-9}{4} = \frac{27}{4}$$

$$y = \pm \frac{3\sqrt{3}}{2}$$

$$\therefore \text{Third vertex is } \left(\frac{3}{2}, \frac{3\sqrt{3}}{2}\right) \text{ or } \left(\frac{3}{2}, -\frac{3\sqrt{3}}{2}\right)$$

11. Find the centre of a circle passing through the points (6, -6), (3, -7) and (3, 3). Also find the radius. (Ans: (3, -2), 5 units)

Ans: $OA = OB = OC =$ radius of the circle where O is the centre of the circle and let O be (x, y)

$$OA^2 = OB^2 = OC^2$$

$$OA^2 = (x-6)^2 + (y+6)^2 = x^2 + y^2 - 12x + 36 + 12y + 36$$

$$OB^2 = (x-3)^2 + (y+7)^2 = x^2 + y^2 - 6x + 9 + 14y + 49$$

$$OC^2 = (x-3)^2 + (y-3)^2 = x^2 + y^2 - 6x + 9 - 6y + 9$$

$$OA^2 = OB^2$$

$$x^2 + y^2 - 12x + 12y + 72 = x^2 + y^2 - 6x + 14y + 58$$

$$-12x + 12y + 6x - 14y + 72 - 58 = 0$$

$$-6x - 2y + 14 = 0$$

$$-3x - y + 7 = 0 \quad \dots\dots\dots(1)$$

$$x^2 + y^2 - 6x + 9 + 14y + 49 = x^2 + y^2 - 6x + 9 - 6y + 9$$

$$-6x + 14y + 58 = -6x - 6y + 18$$

$$14y + 6y = 18 - 58$$

$$20y = -40$$

$$y = -2 \quad \dots\dots\dots(2)$$

Substituting we get

$$-3x + 2 + 7 = 0$$

$$-3x = -9$$

$$x = 3$$

$$(x, y) = (3, -2)$$

$$\text{Diameter} = 3^2 + 2^2 - 6(3) + 18 - 6(-2)$$

$$= 9 + 4 - 18 + 18 + 12$$

$$= 13 + 12 = 25$$

$$\text{Radius} = \sqrt{25} = 5 \text{ units}$$

12. The two opposite vertices of a square are (-1, 2) and (3, 2). Find the coordinates of the other two vertices. (Ans: (1, 0), (1, 4))

Ans: $AB = BC \Rightarrow AD^2 = BC^2$

$$(x+1)^2 + (y-2)^2 = (x-3)^2 + (y-2)^2$$

$$x^2 + 2x + 1 + y^2 - 4y + 4 = x^2 - 6x + 9 + y^2 - 4y + 4$$

$$2x - 4y + 5 = -6x - 4y + 13$$

$$8x = 13 - 5 \quad 8x = 8 \Rightarrow x = 1$$

On substituting in $(x-3)^2 + (y-2)^2 + (x+1)^2 + (y-2)^2$

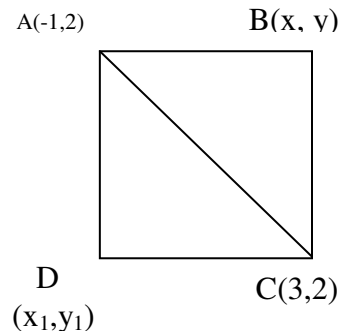

$$= (-1 - 3)^2 + (2 - 2)^2$$

We get $y = 4$ or 0 .

$\therefore B(1, 4)$ or $(1, 0)$

$$AD = DC \Rightarrow AD^2 = DC^2$$

$$(x_1 + 1)^2 + (y_1 - 2)^2 = (x_1 - 3)^2 + (y_1 - 2)^2$$

$\therefore x = 1$.

$$\text{On substituting in } (x_1 + 1)^2 + (y_1 - 2)^2 + (x_1 - 3)^2 + (y_1 - 2)^2 = 16$$

We get $y_1 = 0$ or 4 .

$\therefore D(1, 4)$ or $(1, 0)$

\therefore the opposite vertices are $(1, 4)$ & $(1, 0)$

13. Find the coordinates of the point P which is three-fourth of the way from A (3, 1)

to B (-2, 5).

$$(\text{Ans: } \left(-\frac{3}{4}, 4\right))$$

Ans : Hint: Ratio AP:PB = 3 : 1

14. The midpoint of the line joining (2a, 4) and (-2, 3b) is (1, 2a + 1). Find the values of a & b.

$$(\text{Ans: } a = 2, b = 2)$$

Ans : A(2a, 4) P(1, 2a + 1) B(-2, 3b)

$$\frac{2a - 2}{2} = 1 \quad \& \quad \frac{4 + 3b}{2} = 2a + 1$$

We get $a = 2$ & $b = 2$.

15. Find the distance between the points (b + c, c + a) and (c + a, a + b) .

$$(\text{Ans : } \sqrt{a^2 + 2b^2 + c^2 - 2ab - 2bc})$$

Ans : Use distance formula

16. Find the relation between x and y when the point (x,y) lies on the straight line joining the points (2,-3) and (1,4) [Hint: Use area of triangle is 0]

Ans : Hint: If the points are on straight line, area of the triangle is zero.

17. Find the distance between $(\cos\theta, \sin\theta)$ and $(\sin\theta, -\cos\theta)$.

$$(\text{Ans: } \sqrt{2})$$

$$\text{Ans : } \sqrt{(\cos\theta - \sin\theta)^2 + (\sin\theta + \cos\theta)^2}$$

On simplifying we get $\sqrt{2}$

18. Find the distance between $(a \cos 35^\circ, 0)$ $(0, a \cos 65^\circ)$.

$$(\text{Ans: } a)$$

)

Ans : Proceed as in sum no.17.

19. The vertices of a ΔABC are A(4, 6), B(1, 5) and C(7, 2). A line is drawn to intersect sides AB and AC at D and E respectively, such that $\frac{AD}{AB} = \frac{AE}{AC} = \frac{1}{4}$. Calculate the area of the ΔADE and compare it with the area of ΔABC .
(Ans: $\frac{15}{32}$ sq units; 1:16)

Ans : Hint : $\frac{AD}{AB} = \frac{AE}{AC} = \frac{1}{4}$

$\therefore AD : DB = 1 : 3$ & $AE : EC = 1 : 3$

Find D & E and find area of triangle ADE and triangle ABC and compare.

20. Plot the points A(2,0) and B (6,0) on a graph paper. Complete an equilateral triangle ABC such that the ordinate of C be a positive real number .Find the coordinates of C

(Ans: $(4, 2\sqrt{3})$)

Ans : Proceed by taking C(x, y)
 $AC = BC = AB$

21. Find the ratio in which the line segment joining A(6,5) and B(4,-3) is divided by the line $y=2$
(Ans:3:5)

Ans : Let the ratio be k:1

$$x = \frac{4k + 6}{k + 1}$$

$$y = \frac{-3k + 5}{k + 1}$$

$$\frac{-3k + 5}{k + 1} = 2$$

On solving we get $k = 3 : 5$

22. The base BC of an equilateral triangle ABC lies on the y-axis. The coordinates of C are (0,-3). If the origin is the midpoint of BC find the coordinates of points A and B.

Ans : Hint : The point A will lie on the x axis. Find A using $AB = BC = AC$.
Coordinates of B (0, 3)

SIMILAR TRIANGLES

Geometry is the right foundation of all painting, I have decided to teach its rudiments and principles to all youngsters eager for art.

1. ABC is a right-angled triangle, right-angled at A. A circle is inscribed in it. The lengths of the two sides containing the right angle are 6cm and 8 cm. Find the radius of the in circle.

(Ans: $r=2$)

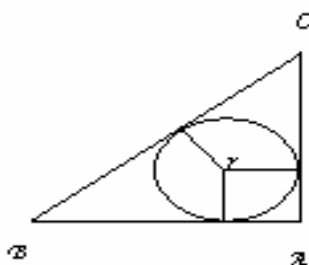

Ans: $BC = 10\text{cm}$
 $y + z = 8\text{cm}$
 $x + z = 6\text{cm}$
 $x + y = 10$
 $\Rightarrow x + y + z = 12$
 $z = 12 - 10$
 $z = 2\text{ cm}$
 $\therefore \text{radius} = 2\text{cm}$

2. ABC is a triangle. PQ is the line segment intersecting AB in P and AC in Q such that PQ parallel to BC and divides triangle ABC into two parts equal in area. Find BP: AB.

Ans: Refer example problem of text book.

7. Find the length of the second diagonal of a rhombus, whose side is 5cm and one of the diagonals is 6cm. (Ans: 8cm)

Ans: Length of the other diagonal = 2(BO)
 where BO = 4cm
 \therefore BD = 8cm.

8. Prove that three times the sum of the squares of the sides of a triangle is equal to four times the sum of the squares of the medians of the triangle.

Ans: To prove $3(AB^2 + BC^2 + CA^2) = 4(AD^2 + BE^2 + CF^2)$
 In any triangle sum of squares of any two sides is equal to twice the square of half of third side, together with twice the square of median bisecting it.

If AD is the median

$$AB^2 + AC^2 = 2 \left\{ AD^2 + \frac{BC^2}{4} \right\}$$

$$2(AB^2 + AC^2) = 4AD^2 + BC^2$$

Similarly by taking BE & CF as medians we get

$$\Rightarrow 2(AB^2 + BC^2) = 4BE^2 + AC^2$$

$$\& 2(AC^2 + BC^2) = 4CF^2 + AB^2$$

Adding we get

$$\Rightarrow 3(AB^2 + BC^2 + AC^2) = 4(AD^2 + BE^2 + CF^2)$$

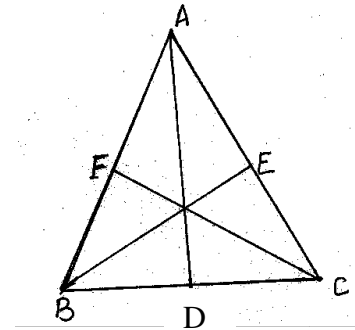

9. ABC is an isosceles triangle in which AB=AC=10cm. BC=12. PQRS is a rectangle inside the isosceles triangle. Given PQ=SR= y cm, PS=QR=2x. Prove that $x = 6 - \frac{3y}{4}$.

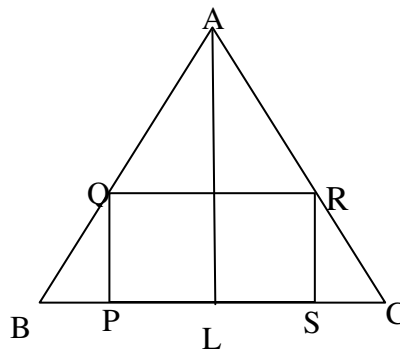

Ans: AL = 8 cm
 $\Delta BPQ \sim \Delta BAL$
 $\Rightarrow \frac{BQ}{PQ} = \frac{BL}{AL}$

$$\Rightarrow \frac{6-x}{y} = \frac{6}{8}$$

$$\Rightarrow x = 6 - \frac{3y}{4}$$

Hence proved

10. If ABC is an obtuse angled triangle, obtuse angled at B and if $AD \perp CB$

Prove that $AC^2 = AB^2 + BC^2 + 2BC \times BD$

Ans: $AC^2 = AD^2 + CD^2$
 $= AD^2 + (BC + BD)^2$
 $= AD^2 + BC^2 + 2BC \cdot BD + BD^2$
 $= AB^2 + BC^2 + 2BC \cdot BD$

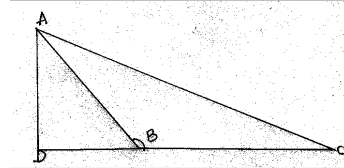

11. If ABC is an acute angled triangle, acute angled at B and $AD \perp BC$

prove that $AC^2 = AB^2 + BC^2 - 2BC \times BD$

Ans: Proceed as sum no. 10.

12. Prove that in any triangle the sum of the squares of any two sides is equal to twice the square of half of the third side together with twice the square of the median, which bisects the third side.

Ans: To prove $AB^2 + AC^2 = 2AD^2 + 2\left(\frac{1}{2}BC\right)^2$

Draw $AE \perp BC$

Apply property of Q. No.10 & 11.

In ΔABD since $\angle D > 90^\circ$

$$\therefore AB^2 = AD^2 + BD^2 + 2BD \times DE \dots(1)$$

ΔACD since $\angle D < 90^\circ$

$$AC^2 = AD^2 + DC^2 - 2DC \times DE \dots(2)$$

Adding (1) & (2)

$$AB^2 + AC^2 = 2(AD^2 + BD^2)$$

$$= 2\left(AD^2 + \left(\frac{1}{2}BC\right)^2\right)$$

$$\text{Or } AB^2 + AC^2 = 2(AD^2 + BD^2)$$

Hence proved

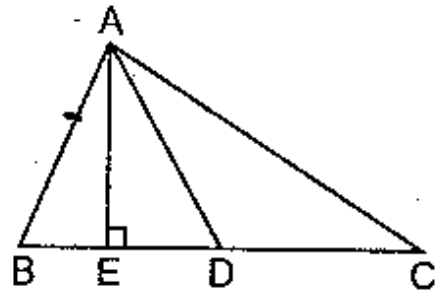

13. If A be the area of a right triangle and b one of the sides containing the right angle, prove that the length of the altitude on the hypotenuse is $\frac{2Ab}{\sqrt{b^4 + 4A^2}}$.

Ans: Let QR = b
 $A = \text{Ar}(\Delta PQR)$
 $A = \frac{1}{2} \times b \times PQ$
 $PQ = \frac{2A}{b}$ (1)
 $\Delta PNQ \sim \Delta PQR$ (AA)
 $\Rightarrow \frac{PQ}{PR} = \frac{NQ}{QR}$ (2)
 From ΔPQR
 $PQ^2 + QR^2 = PR^2$
 $\frac{4A^2}{b^2} + b^2 = PR^2$
 $PR = \sqrt{\frac{4A^2 + b^4}{b^2}} = \frac{\sqrt{4A^2 + b^4}}{b}$
 Equation (2) becomes
 $\frac{2A}{b \times PR} = \frac{NQ}{b}$
 $NQ = \frac{2A}{PR}$
 $NQ = \frac{2Ab}{\sqrt{4A^2 + b^4}}$ Ans

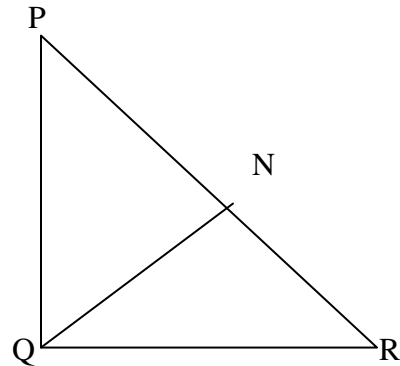

14. ABC is a right triangle right-angled at C and $AC = \sqrt{3} BC$. Prove that $\angle ABC = 60^\circ$.

Ans: $\tan B = \frac{AC}{BC}$
 $\tan B = \frac{\sqrt{3}BC}{BC}$
 $\tan B = \sqrt{3}$
 $\Rightarrow \tan B = \tan 60$
 $\Rightarrow B = 60^\circ$

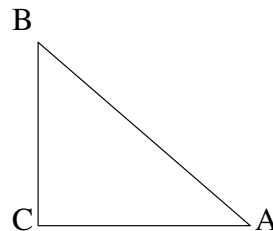

$\Rightarrow \angle ABC = 60^\circ$
Hence proved

15. ABCD is a rectangle. $\triangle ADE$ and $\triangle ABF$ are two triangles such that $\angle E = \angle F$ as shown in the figure. Prove that $AD \times AF = AE \times AB$.

Ans: Consider $\triangle ADE$ and $\triangle ABF$
 $\angle D = \angle B = 90^\circ$
 $\angle E = \angle F$ (given)
 $\therefore \triangle ADE \cong \triangle ABF$
 $\frac{AD}{AB} = \frac{AE}{AF}$
 $\Rightarrow AD \times AF = AB \times AE$
 Proved

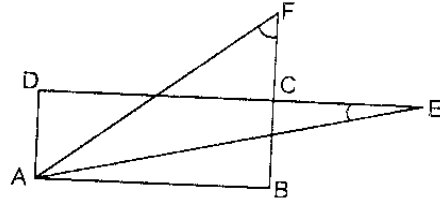

16. In the given figure, $\angle AEF = \angle AFE$ and E is the mid-point of CA. Prove that

$$\frac{BD}{CD} = \frac{BF}{CE}$$

Ans: Draw $CG \parallel DF$
 In $\triangle BDF$
 $CG \parallel DF$
 $\therefore \frac{BD}{CD} = \frac{BF}{GF}$ (1) BPT
 In $\triangle AFE$
 $\angle AEF = \angle AFE$
 $\Rightarrow AF = AE$
 $\Rightarrow AF = AE = CE$(2)

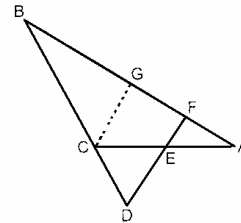

In $\triangle ACG$
 E is the mid point of AC
 $\Rightarrow FG = AF$

\therefore From (1) & (2)

$$\frac{BD}{CD} = \frac{BF}{CE}$$

Hence proved

17. ABCD is a parallelogram in the given figure, AB is divided at P and CD and Q so that AP:PB=3:2 and CQ:QD=4:1. If PQ meets AC at R, prove that $AR = \frac{3}{7} AC$.

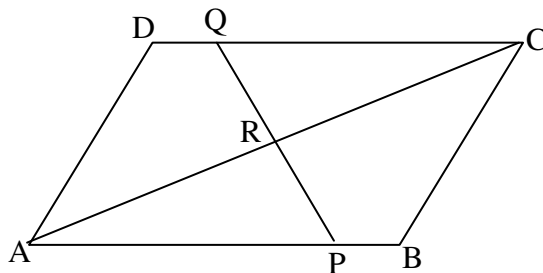

Ans: $\triangle APR \sim \triangle CQR$ (AA)

$$\Rightarrow \frac{AP}{CQ} = \frac{PR}{QR} = \frac{AR}{CR}$$

$$\Rightarrow \frac{AP}{CQ} = \frac{AR}{CR} \quad \& \quad AP = \frac{3}{5} AB$$

$$\Rightarrow \frac{3AB}{5CQ} = \frac{AR}{CR} \quad \& \quad CQ = \frac{4}{5} CD = \frac{4}{5} AB$$

$$\Rightarrow \frac{AR}{CR} = \frac{3}{4}$$

$$\Rightarrow \frac{CR}{AR} = \frac{4}{3}$$

$$\frac{CR + AR}{AR} = \frac{4}{3} + 1$$

$$\Rightarrow \frac{AC}{AR} = \frac{7}{3}$$

$$\Rightarrow AR = \frac{3}{7} AC$$

Hence proved

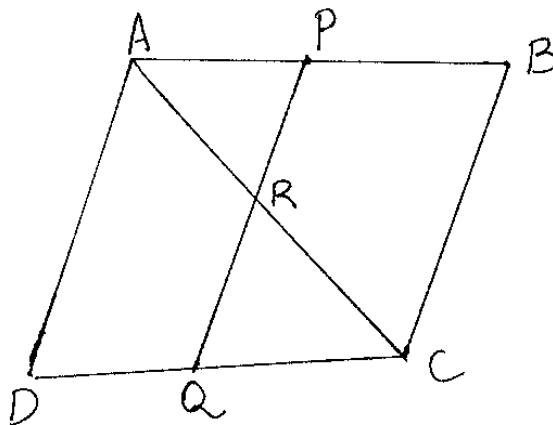

18. Prove that the area of a rhombus on the hypotenuse of a right-angled triangle, with one of the angles as 60° , is equal to the sum of the areas of rhombuses with one of their angles as 60° drawn on the other two sides.

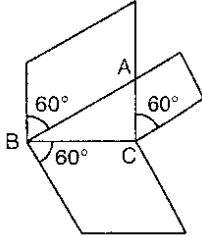

Ans: Hint: Area of Rhombus of side a & one angle of 60°

$$= \frac{\sqrt{3}}{2} \times a \times a = \frac{\sqrt{3}}{2} a^2$$

19. An aeroplane leaves an airport and flies due north at a speed of 1000 km/h. At the same time, another plane leaves the same airport and flies due west at a speed of 1200 km/h. How far apart will be the two planes after $1\frac{1}{2}$ hours. (Ans: $300\sqrt{61}$ Km)

Ans: $ON = 1500$ km (dist = $s \times t$)

$$OW = 1800 \text{ km}$$

$$NW = \sqrt{1500^2 + 1800^2}$$

$$= \sqrt{5490000}$$

$$= 300\sqrt{61} \text{ km}$$

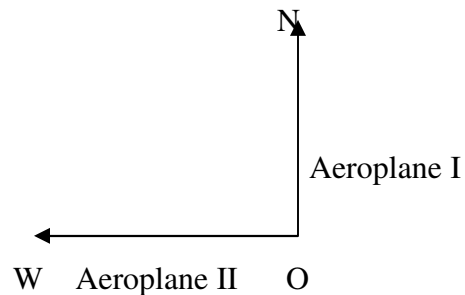

20. ABC is a right-angled isosceles triangle, right-angled at B. AP, the bisector of $\angle BAC$, intersects BC at P. Prove that $AC^2 = AP^2 + 2(1+\sqrt{2})BP^2$

Ans: $AC = \sqrt{2} AB$ (Since $AB = BC$)

$$\frac{AB}{AC} = \frac{BP}{CP} \text{ (Bisector Theorem)}$$

$$\Rightarrow CP = \sqrt{2} BP$$

$$AC^2 - AP^2 = AC^2 - (AB^2 + BP^2)$$

$$= AC^2 - AB^2 - BP^2$$

$$= BC^2 - BP^2$$

$$= (BP + PC)^2 - BP^2$$

$$= (BP + \sqrt{2} BP)^2 - BP^2$$

$$= 2BP^2 + 2\sqrt{2} BP^2$$

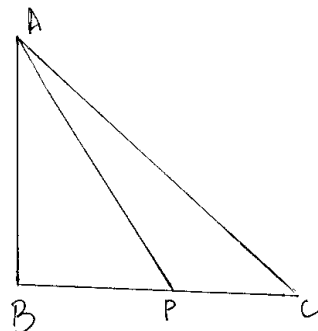

$$= 2(\sqrt{2} + 1)BP^2 \Rightarrow AC^2 = AP^2 + 2(1 + \sqrt{2})BP^2$$

Proved

UNIT-9

CIRCLES

1. Prove that the parallelogram circumscribing a circle is rhombus.

Ans Given : ABCD is a parallelogram circumscribing a circle.
To prove : - ABCD is a rhombus

or
 $AB = BC = CD = DA$

Proof: Since the length of tangents from external are equal in length

$$\begin{aligned} \therefore AS &= AR && \dots(1) \\ BQ &= BR && \dots(2) \\ QC &= PC && \dots(3) \\ SD &= DP && \dots(4) \end{aligned}$$

Adding (1), (2), (3) & (4).

$$AS + SD + BQ + QC = AR + BR + PC + DP$$

$$AD + BC = AB + DC$$

$$AD + AD = AB + AB$$

Since $BC = AD$ & $DC = AB$ (opposite sides of a parallelogram are equal)

$$2AD = 2AB$$

$$\therefore AD = AB \quad \dots(5)$$

$$BC = AD \left\{ \begin{array}{l} \text{(opposite sides of a parallelogram)} \\ \dots(6) \end{array} \right.$$

$$DC = AB \left\{ \begin{array}{l} \dots(6) \end{array} \right.$$

From (5) and (6)

$$AB = BC = CD = DA$$

Hence proved

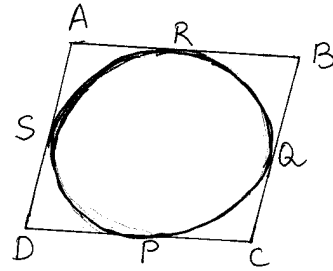

2. A circle touches the side BC of a triangle ABC at P and touches AB and AC when produced at Q and R respectively as shown in figure.

Show that $AQ = \frac{1}{2}$ (perimeter of triangle ABC)

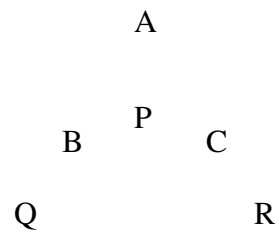

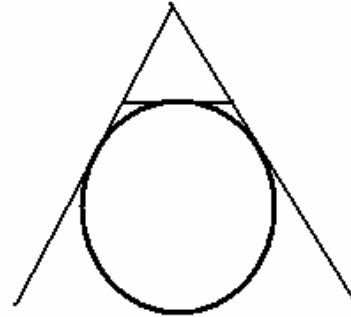

Ans: Since the length of tangents from external point to a circle are equal.

$$AQ = AR$$

$$BQ = BP$$

$$PC = CR$$

Since $AQ = AR$

$$AB + BQ = AC + CR$$

$$\therefore AB + BP = AC + PC \text{ (Since } BQ = BP \text{ \& } PC = CR)$$

$$\text{Perimeter of } \triangle ABC = AB + AC + BC$$

$$= AB + BP + PC + AC$$

$$= AQ + PC + AC \text{ (Since } AB + BP = AQ)$$

$$= AQ + AB + BP \text{ (Since } PC + AC = AB + BP)$$

$$= AQ + AQ \text{ (Since } AB + BP = AQ)$$

$$\text{Perimeter of } \triangle ABC = 2AQ$$

$$\therefore AQ = \frac{1}{2} \text{ (perimeter of triangle ABC)}$$

3. In figure, XP and XQ are tangents from X to the circle with centre O. R is a point on the circle. Prove that $XA + AR = XB + BR$

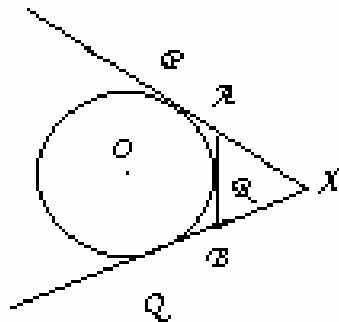

Ans: Since the length of tangents from external point to a circle are equal

$$XP = XQ$$

$$PA = RA$$

$$BQ = BR$$

$$XP = XQ$$

$$\Rightarrow XA + PA = XB + BQ$$

$$\Rightarrow XA + AR = XB + BR (\ominus PA = AR \ \& \ BQ = BR)$$

Hence proved

4. In figure, the incircle of triangle ABC touches the sides BC, CA, and AB at D, E, and F respectively. Show that $AF+BD+CE=AE+BF+CD=\frac{1}{2}$ (perimeter of triangle ABC),

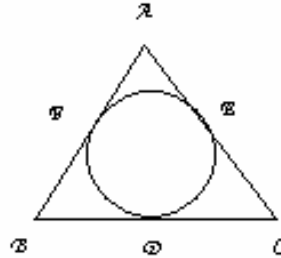

Ans: Since the length of tangents from an external point to are equal

$$\begin{aligned} \therefore AF &= AE \\ FB &= BD \\ EC &= CD \end{aligned}$$

$$\begin{aligned} \text{Perimeter of } \triangle ABC &= AB + BC + AC \\ &= AF + FB + BD + DC + AE + EC \\ &= AF + BD + BD + CE + AF + CE \\ &\quad (\ominus AF=AE, FB=BD, EC=CD) \\ &= AF + AF + BD + BD + CE + CE \end{aligned}$$

$$\begin{aligned} \text{Perimeter of } \triangle ABC &= 2(AF + BD + CE) \\ \therefore AF + BD + CE &= \frac{1}{2} (\text{perimeter of } \triangle ABC) \dots\dots\dots(1) \end{aligned}$$

$$\begin{aligned} \text{Perimeter of } \triangle ABC &= AB + BC + AC \\ &= AF + FB + BD + DC + AE + EC \\ &= AE + BF + BF + CD + AE + CD \\ &\quad (\ominus AF = AE, FB = BD, EC = CD) \\ &= AE + AE + BF + BF + CD + CD \end{aligned}$$

$$\begin{aligned} \text{Perimeter of } \triangle ABC &= 2(AE + BF + CD) \\ \therefore AE + BF + CD &= \frac{1}{2} (\text{perimeter of } \triangle ABC) \dots\dots\dots(2) \end{aligned}$$

From (1) and (2)

$$AF + BD + CE = AE + BF + CD = \frac{1}{2} (\text{perimeter of } \triangle ABC)$$

5. A circle touches the sides of a quadrilateral ABCD at P, Q, R and S respectively. Show that the angles subtended at the centre by a pair of opposite sides are supplementary.

Ans: To prove :- $\angle AOB + \angle DOC = 180^\circ$
 $\angle BOC + \angle AOD = 180^\circ$

Proof : - Since the two tangents drawn from an external point to a circle subtend equal angles at centre.

$$\therefore \angle 1 = \angle 2, \angle 3 = \angle 4, \angle 5 = \angle 6, \angle 7 = \angle 8$$

$$\text{but } \angle 1 + \angle 2 + \angle 3 + \angle 4 + \angle 5 + \angle 6 + \angle 7 + \angle 8 = 360^\circ$$

$$2(\angle 2 + \angle 3 + \angle 6 + \angle 7) = 360^\circ$$

$$\angle 2 + \angle 3 + \angle 6 + \angle 7 = 360^\circ$$

$$\therefore \angle AOB + \angle DOC = 180^\circ$$

Similarly

$$\angle 1 + \angle 2 + \angle 3 + \angle 4 + \angle 5 + \angle 6 + \angle 7 + \angle 8 = 360^\circ$$

$$2(\angle 1 + \angle 8 + \angle 4 + \angle 5) = 360^\circ$$

$$\angle 1 + \angle 8 + \angle 5 = 180^\circ$$

$$\therefore \angle BOC + \angle AOD = 180^\circ$$

Hence proved

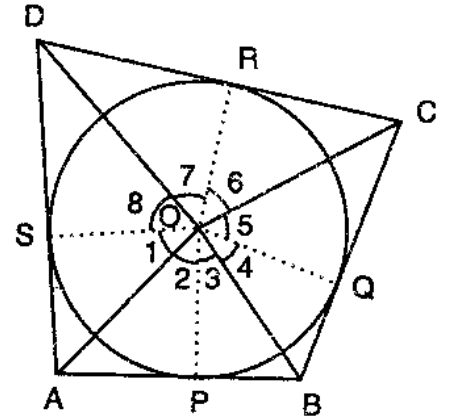

6. In figure, O is the centre of the Circle .AP and AQ two tangents drawn to the circle. B is a point on the tangent QA and $\angle PAB = 125^\circ$, Find $\angle POQ$.
 (Ans: 125°)

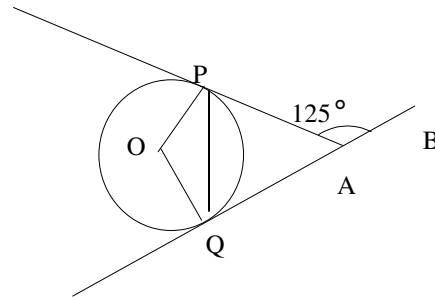

Ans: Given $\angle PAB = 125^\circ$

To find :- $\angle POQ = ?$

Construction :- Join PQ

Proof :- $\angle PAB + \angle PAQ = 180^\circ$ (Linear pair)

$$\angle PAQ + 125^\circ = 180^\circ$$

$$\angle PAQ = 180^\circ - 125^\circ$$

$$\angle PAQ = 55^\circ$$

Since the length of tangent from an external point to a circle are equal.

$$PA = QA$$

\therefore From ΔPAQ

$$\angle APQ = \angle AQP$$

In $\triangle APQ$

$$\angle APQ + \angle AQP + \angle PAQ = 180^\circ \text{ (angle sum property)}$$

$$\angle APQ + \angle AQP + 55^\circ = 180^\circ$$

$$2\angle APQ = 180^\circ - 55^\circ \text{ (}\ominus \angle APQ = \angle AQP\text{)}$$

$$\angle APQ = \frac{125^\circ}{2}$$

$$\therefore \angle APQ = \angle AQP = \frac{125^\circ}{2}$$

OQ and OP are radii

QA and PA are tangents

$$\therefore \angle OQA = 90^\circ$$

$$\& \angle OPA = 90^\circ$$

$$\angle OPQ + \angle QPA = \angle OPA = 90^\circ \text{ (Linear Pair)}$$

$$\angle OPQ + \frac{125^\circ}{2} = 90^\circ$$

$$\angle OPQ = 90^\circ - \frac{125^\circ}{2}$$

$$= \frac{180^\circ - 125^\circ}{2}$$

$$\angle OPQ = \frac{55^\circ}{2}$$

Similarly $\angle OQP + \angle PQA = \angle OQA$

$$\angle OQP + \frac{125^\circ}{2} = 90^\circ$$

$$\angle OQP = 90^\circ - \frac{125^\circ}{2}$$

$$\angle OQP = \frac{55^\circ}{2}$$

In $\triangle POQ$

$$\angle OQP + \angle OPQ + \angle POQ = 180^\circ \text{ (angle sum property)}$$

$$\frac{55^\circ}{2} + \frac{55^\circ}{2} + \angle POQ = 180^\circ$$

$$\angle POQ + \frac{110}{2} = 180^\circ$$

$$\angle POQ = 180^\circ - \frac{110}{2}$$

$$\angle POQ = \frac{360^\circ - 110^\circ}{2}$$

$$\angle POQ = \frac{250^\circ}{2}$$

$$\angle POQ = 125^\circ$$

$$\therefore \angle POQ = 125^\circ$$

7. Two tangents PA and PB are drawn to the circle with center O, such that $\angle APB = 120^\circ$. Prove that $OP = 2AP$.

Ans: Given :- $\angle APB = 120^\circ$
 Construction :- Join OP
 To prove :- $OP = 2AP$
 Proof :- $\angle APB = 120^\circ$
 $\therefore \angle APO = \angle OPB = 60^\circ$
 $\cos 60^\circ = \frac{AP}{OP}$
 $\frac{1}{2} = \frac{AP}{OP}$
 $\therefore OP = 2AP$
 Hence proved

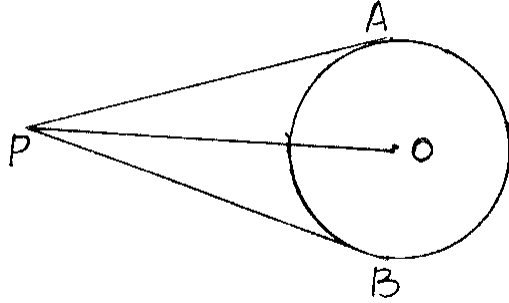

8. From a point P, two tangents PA and PB are drawn to a circle with center O. If $OP = \text{diameter}$ of the circle show that triangle APB is equilateral.

Ans: $PA = PB$ (length of tangents from an external point)
 From $\triangle OAP$,
 $\sin \angle APO = \frac{OA}{OP} = \frac{1}{2}$
 Since $OP = 2OA$ (Since $OP = \text{Diameter}$)
 $\therefore \angle APO = 30^\circ$
 since $\triangle APO \cong \triangle BPO$
 $\angle APO = \angle BPO = 30^\circ$
 $\therefore \angle APB = 60^\circ$
 $\triangle APB$ is equilateral

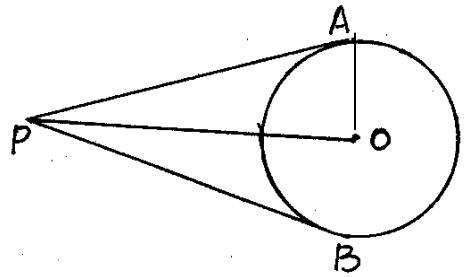

9. In the given fig OPQR is a rhombus, three of its vertices lie on a circle with centre O. If the area of the rhombus is $32\sqrt{3} \text{ cm}^2$. Find the radius of the circle.

Ans: $QP = OR$
 $OP = OQ$
 $\therefore \triangle OPQ$ is an equilateral Δ .
 area of rhombus = 2 (ar of $\triangle OPQ$)
 $32\sqrt{3} = 2 \left(\frac{\sqrt{3}r^2}{4} \right)$

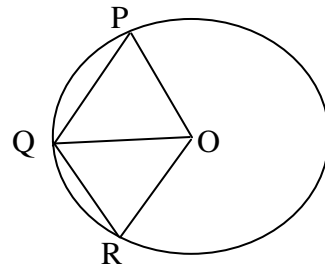

$$32\sqrt{3} = \frac{\sqrt{3}r^2}{2}$$

$$r^2 = 32 \times 2 = 64$$

$$\Rightarrow r = 8\text{cm}$$

$$\therefore \text{Radius} = 8\text{cm}$$

10. If PA and PB are tangents to a circle from an outside point P, such that PA=10cm and $\angle APB=60^\circ$. Find the length of chord AB.

Self Practice

11. The radius of the in circle of a triangle is 4cm and the segments into which one side is divided by the point of contact are 6cm and 8cm. Determine the other two sides of the triangle.

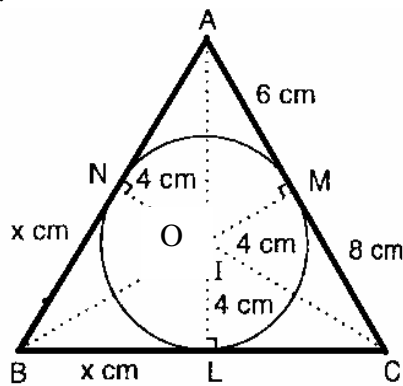

(Ans: 15, 13)

Ans: $a = BC = x + 8$
 $b = AC = 6 + 8 = 14\text{cm}$
 $c = AB = x + 6$

$$\text{Semi-perimeter} = \frac{a+b+c}{2}$$

$$= \frac{BC+AC+AB}{2}$$

$$= \frac{x+8+14+x+6}{2}$$

$$= \frac{2x+28}{2}$$

$$= x+14$$

$$\text{Area of } \Delta ABC = \sqrt{s(s-a)(s-b)(s-c)} \text{ on substituting we get}$$

$$= \sqrt{(x+14)(6)(x)(8)}$$

$$= \sqrt{(x+14)(48x)} \quad \dots\dots\dots(1)$$

Area of $\Delta ABC = \text{area } \Delta AOB + \text{area } \Delta BOC + \text{area } \Delta AOC$

$$\text{area } \Delta AOC = \left(\frac{1}{2}bh\right) = \frac{1}{2} \times 4 \times 14$$

$$= 28$$

On substituting we get

$$\therefore \text{area } \Delta ABC = \text{area } \Delta AOC + \text{area } \Delta BOC + \text{area } \Delta AOB$$

$$= 4x + 56 \quad \dots\dots\dots(2)$$

From (1) and (2)

$$4x + 56 = \sqrt{(x+14)(48x)}$$

Simplify we get $x = 7$

$\therefore AB = x + 6 = 7 + 6 = 13\text{cm}$

$\therefore BC = x + 8 = 7 + 8 = 15\text{cm}$

12. A circle is inscribed in a triangle ABC having sides 8cm, 10cm and 12cm as shown in the figure. Find AD, BE and CF. (Ans :7cm ,5cm,3cm)

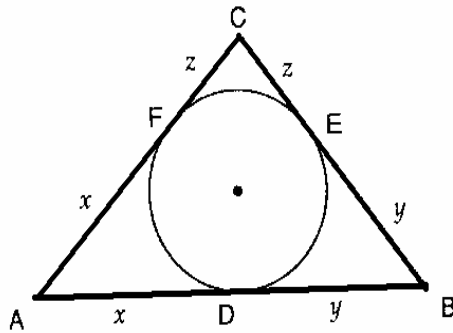

Self Practice

13. Prove that the intercept of a tangent between two parallel tangents to a circle subtends a right angle at the centre.

Since $\Delta ADF \cong \Delta DFC$

$$\angle ADF = \angle CDF$$

$$\therefore \angle ADC = 2 \angle CDF$$

Similarly we can prove $\angle CEB = 2 \angle CEF$

Since $l \parallel m$

$$\angle ADC + \angle CEB = 180^\circ$$

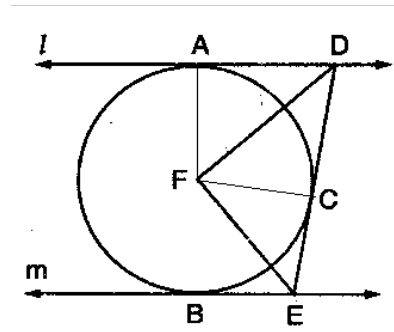
$$\Rightarrow 2\angle CDF + 2\angle CEF = 180^\circ$$

$$\Rightarrow \angle CDF + \angle CEF = 90^\circ$$

In $\triangle DFE$

$$\angle DFE = 90^\circ$$

14. Prove that opposite sides of a quadrilateral circumscribing a circle subtend supplementary angles at the centre of the circle.

Ans: Same as question No.5

15. QR is the tangent to the circle whose centre is P. If $QA \parallel RP$ and AB is the diameter, prove that RB is a tangent to the circle.

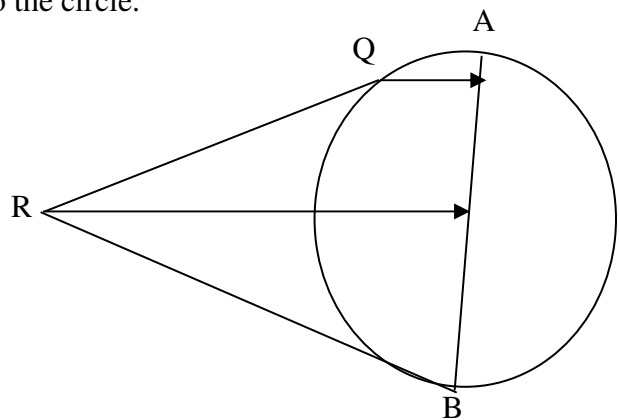

Self Practice

CONSTRUCTIONS**Questions for self practice**

1. Draw a line segment AB of length 4.4cm. Taking A as centre, draw a circle of radius 2cm and taking B as centre, draw another circle of radius 2.2cm. Construct tangents to each circle from the centre of the other circle.
2. Draw a pair of tangents to a circle of radius 2cm that are inclined to each other at an angle of 90° .
3. Construct a tangent to a circle of radius 2cm from a point on the concentric circle of radius 2.6cm and measure its length. Also, verify the measurements by actual calculations. (length of tangent = 2.1cm)
4. Construct an isosceles triangle whose base is 7cm and altitude 4cm and then construct another similar triangle whose sides are $\frac{1}{2}$ times the corresponding sides of the isosceles triangle.
5. Draw a line segment AB of length 8cm. taking A as center, draw a circle of radius 4cm and taking B as centre, draw another circle of radius 3cm. Construct tangents to each circle from the center of the other circle.

MENSURATION

AREAS RELATED TO CIRCLES

The mathematical sciences particularly exhibit order, symmetry, and limitation; and these are the greatest forms of the beautiful.

1. In the adjoining figure $\triangle ABC$ right angled triangle right angled at A. Semi circles are drawn on the sides of the triangle $\triangle ABC$. Prove that area of the Shaded region is equal to area of $\triangle ABC$

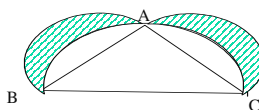

Ans: Refer CBSE paper 2008

2. The sum of the diameters of two circles is 2.8 m and their difference of circumferences is 0.88m. Find the radii of the two circles (Ans: 77, 63)

Ans: $d_1 + d_2 = 2.8 \text{ m} = 280\text{cm}$
 $r_1 + r_2 = 140$
 $2 \pi (r_1 - r_2) = 0.88\text{m} = 88\text{cm}$
 $r_1 - r_2 = \frac{88}{2\pi} = \frac{88 \times 7}{44} = 2 \times 7 = 14$
 $r_1 + r_2 = 140$
 $r_1 - r_2 = 14$

 $2r_1 = 154$
 $r_1 = 77$
 $r_2 = 140 - 77 = 63$
 $r_1 = 77 \text{ cm}, r_2 = 63\text{cm}$

- 3 Find the circumference of a circle whose area is 16 times the area of the circle with diameter 7cm (Ans: 88cm)

Ans: $\pi R^2 = 16 \pi r^2$
 $R^2 = 16 r^2$
 $R^2 = 16 \times \frac{7}{2} \times \frac{7}{2}$
 $= 49 \times 4 \Rightarrow R = 7 \times 2 = 14\text{cm}$
Circumference = $2 \times \frac{22}{7} \times 14 = 2 \times 22 \times 2 = 88 \text{ cm}$

4. Find the area enclosed between two concentric circles of radii 3.5cm, 7cm. A third concentric circle is drawn outside the 7cm circle so that the area enclosed between it and the 7cm circle is same as that between two inner circles. Find the radius of the third circle
(Ans: 115.5 cm^2 $r = \sqrt{343} / 2$)

Ans: Area between first two circles = $\Pi \times 7^2 - \Pi \times 3.5^2$
 $= 49 \Pi - 12.25 \Pi$ -----(1)

Area between next two circles = $\Pi r^2 - \Pi \times 7^2$
 $= \Pi r^2 - 49 \Pi$ -----(2)

(1) & (2) are equal

$49 \Pi - 12.25 \Pi = \Pi r^2 - 49 \Pi$

$\Pi r^2 = 49 \Pi + 49 \Pi - 12.25 \Pi$

$\therefore r^2 = 98 - 12.25 = 85.75$

$r^2 = \frac{8575}{100} = \frac{343}{4}$

$r = \frac{\sqrt{343}}{2} \text{ cm.}$

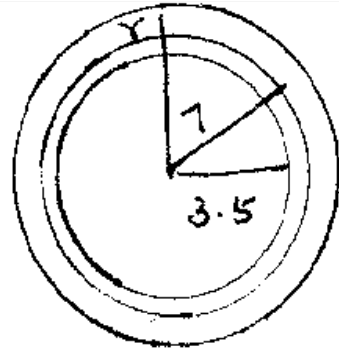

5. Two circles touch externally. The sum of their areas is $58\pi \text{ cm}^2$ and the distance between their centres is 10 cm. Find the radii of the two circles. (Ans: 7cm, 3cm)

Ans: Sum of areas = $\Pi r^2 + \Pi (10 - r)^2 = 58 \Pi$

$\Pi r^2 + \Pi (100 - 20r + r^2) = 58 \Pi$

$r^2 + 100 - 20r + r^2 = 58$

$2r^2 - 20r + 100 - 58 = 0$

$2r^2 - 20r + 42 = 0$

$r^2 - 10r + 21 = 0$

$(r-7), (r-3) = 0$

$r=7\text{cm}, 3\text{cm}$

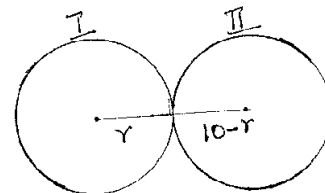

6. From a sheet of cardboard in the shape of a square of side 14 cm, a piece in the shape of letter B is cut off. The curved side of the letter consists of two equal semicircles & the breadth of the rectangular piece is 1 cm. Find the area of the remaining part of cardboard.
(Ans: 143.5 cm^2)

Ans: Area of remaining portion = Area of square – Area of 2 semi circles – Area of rectangle

$= 14 \times 14 - \Pi \times 3.5^2 - 14 \times 1$

$= 196 - \frac{22}{7} \times 3.5 \times 3.5 - 14$

$= 196 - 38.5 - 14 = 143.5 \text{ cm}^2$

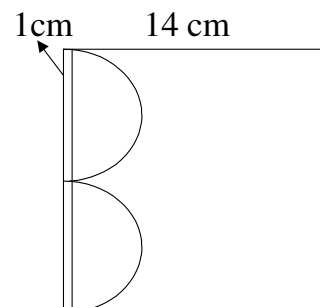

7. A piece of cardboard in the shape of a trapezium ABCD & AB || DE, $\angle BCD = 90^\circ$, quarter circle BFEC is removed. Given AB = BC = 3.5 cm, DE = 2 cm. Calculate the area of remaining piece of cardboard. (Ans: 6.125 cm²)

Ans: Area of remaining portion = Area of trap – Area of quadrant

$$\begin{aligned} &= \frac{1}{2} \times 3.5 (5.5 + 3.5) - \frac{1}{4} \times \frac{22}{7} \times 3.5 \times 3.5 \\ &= 15.75 - \frac{19.25}{2} = 15.75 - 9.625 \\ &= 6.125 \text{ cm}^2 \end{aligned}$$

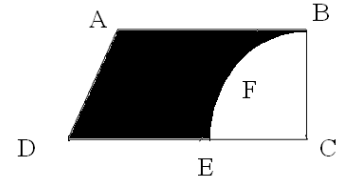

8. In the figure, ABCD is a square inside a circle with centre O. The Centre of the square coincides with O & the diagonal AC is horizontal of AP, DO are vertical &

AP = 45 cm, DQ = 25 cm. Find a) the radius of the circle b) si

c) area of shaded region (use $\pi = 3.14$, $\sqrt{2} = 1.41$)

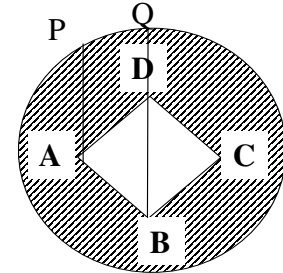

Ans: a) 53cm
b) 39.48cm
c) 7252.26 cm²

Self Practice

9. The area enclosed between two concentric circles is 770cm². If the radius of the outer circle is 21cm, find the radius of the inner circle. (Ans :14cm)

Ans: $\pi R^2 - \pi r^2 = 770$
 $\pi (21^2 - r^2) = 770$
 $21^2 - r^2 = \frac{770}{22} \times 7 = \frac{70}{2} \times 7$
 $r^2 = 441 - \frac{490}{2} = 441 - 245 = 196$
 $r = \pm 14$
 $r = 14\text{cm}$

10. A circular disc of 6 cm radius is divided into three sectors with central angles 120°, 150°, 90°. What part of the circle is the sector with central angles 120°. Also give the ratio of the areas of three sectors. (Ans: $\frac{1}{3}$ (Area of the circle) 4 : 5 : 3)

Ans: Ratio of areas = $\frac{120}{360} \pi \times 6^2 : \frac{150}{360} \pi \times 6^2 : \frac{90}{360} \pi \times 6^2$

$$= 12 \Pi : 15 \Pi : 9 \Pi$$

$$= 4 : 5 : 3$$

$$\text{Area of sector of central angle } 120^\circ = \frac{120^\circ}{360^\circ} \times \Pi r^2$$

(i.e.) $\frac{1}{3}$ of area of the circle.

11. If the minute hand of a big clock is 1.05 m long, find the rate at which its tip is moving in cm per minute. (Ans: 11cm/min)

Ans: Self Practice

12. ABC is a right angled triangle in which $\angle A = 90^\circ$. Find the area of the shaded region if AB = 6 cm, BC=10cm & I is the centre of the Incircle of ΔABC .

$$(\text{Ans: } \frac{80}{7} \text{ sq.cm})$$

Ans: $\angle A = 90^\circ$

$$BC = 10\text{cm}; AB = 6\text{cm};$$

$$\therefore AC = 8\text{cm}$$

$$\text{Area of the } \Delta = \frac{1}{2} \times 6 \times 8 = 24 \text{ cm}^2$$

Let the Radius of the Incircle be r

$$\therefore \frac{1}{2} \times 10 \times r + \frac{1}{2} \times 8 \times r + \frac{1}{2} \times 6 \times r = 24$$

$$\frac{1}{2} r [10 + 8 + 6] = 24$$

$$r = 2 \text{ cm}$$

$$\therefore \text{Area of circle} = \Pi r^2 = \frac{22}{7} \times 2 \times 2 = \frac{88}{7} \text{ cm}^2$$

$$\text{Area of shaded region} = 24 - \frac{88}{7} = \frac{168 - 88}{7} = \frac{80}{7} \text{ cm}^2$$

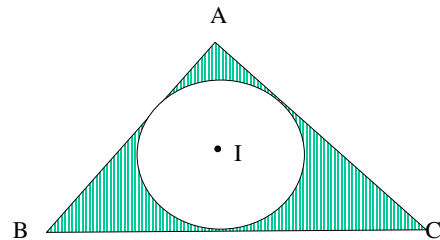

13. Find the perimeter of the figure, where AED is a semi-circle and ABCD is a rectangle. (Ans : 76cm)

Ans: Perimeter of the fig = 20 + 14 + 20 + length of the arc (AED)

$$\text{Length of Arc} = (\Pi \times r) = \frac{22}{7} \times 7 = 22\text{cm}$$

$$\therefore \text{Perimeter of the figure} = 76 \text{ cm}$$

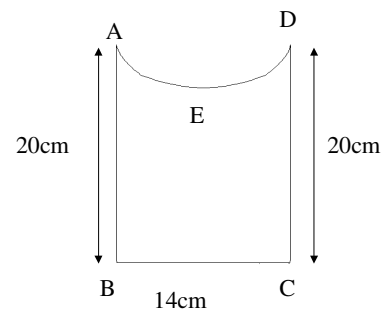

14. Find the area of shaded region of circle of radius =7cm, if $\angle AOB=70^\circ$, $\angle COD=50^\circ$ and $\angle EOF=60^\circ$.

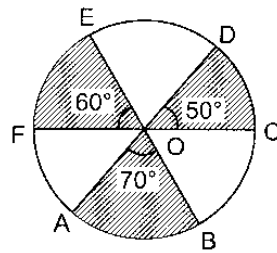

(Ans:77cm²)

Ans: Ar(Sector AOB + Sector COD + Sector OEF)

$$= \frac{70}{360} \pi \times 7^2 + \frac{50}{360} \pi \times 7^2 + \frac{60}{360} \pi \times 7^2$$

$$49 \pi \left(\frac{7}{36} + \frac{5}{36} + \frac{6}{36} \right) = 49 \pi \times \frac{18}{36} = \frac{49}{2} \times \frac{22}{7} = 77 \text{ cm}^2$$

15. What is the ratio of the areas of sectors I and II ?

(Ans:4:5)

Ans: Ratio will be

$$\frac{120}{360} \pi r^2 : \frac{150}{360} \pi r^2$$

$$\frac{4}{12} : \frac{5}{12} = 4:5$$

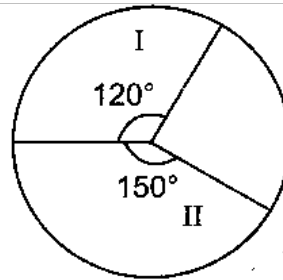

16. Find the area of shaded region, if the side of square is 28cm and radius of the sector is $\frac{1}{2}$ the length of side of square. (Ans:1708cm)

Ans: Area of shaded region is

$$2 \left(\frac{270}{360} \right) \pi \times 14 \times 14 + 28 \times 28$$

$$2 \times \frac{3}{4} \times \frac{22}{7} \times 14 \times 14 + 784$$

$$924 + 784 = 1708 \text{ cm}^2$$

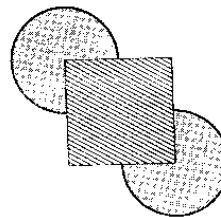

17. If $OA = OB = 14\text{cm}$, $\angle AOB = 90^\circ$, find the area of shaded region. (Ans: 21cm^2)

Ans: Area of the shaded region

= Area of ΔAOB – Area of Semi Circle

$$= \frac{1}{2} \times 14 \times 14 - \frac{1}{2} \times \frac{22}{7} \times 7 \times 7$$

$$98 - 77 = 21 \text{ cm}^2$$

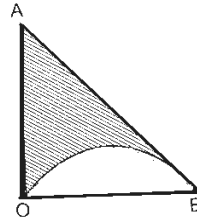

18. The given figure consists of four small semicircles and two big semicircles. If the smaller semicircles are equal in radii and the bigger semicircles are also equal in radii, find the perimeter and the area of the shaded portion of the figure. Given that radius of each bigger semicircle is 42cm .

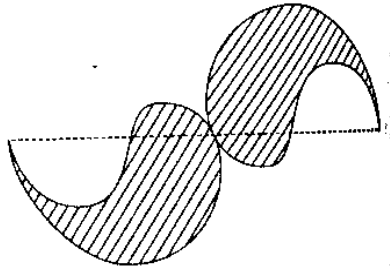

(Ans: 528cm , 5544 sq cm)

Ans: Perimeter of the shaded region

= 2 [Perimeter (Bigger semi circle) + Perimeter (smaller semi circle) + Perimeter (small semi circle)]

$$= 2 (42 \Pi + 21 \Pi + 21 \Pi)$$

$$= 84 \Pi$$

$$= 2 \times 84 \times \frac{22}{7} = 24 \times 22 = 528 \text{ cm}$$

Area of shaded region

= [Area(big semi circle)]

$$= 2 \times \Pi \times 42 \times 42 \times \frac{1}{2} = \frac{22}{7} \times 42 \times 42 = 5544 \text{ cm}^2$$

19. The boundary of the shaded portion in the adjoining figure consists of four half-circles and two quarter-circles. Find the length of the boundary and the area of the shaded portion, if $OA=OB=OC=OD=14\text{cm}$. (Ans: 132 cm, 308 sq cm)

Ans: Proceed as in sum no 18.

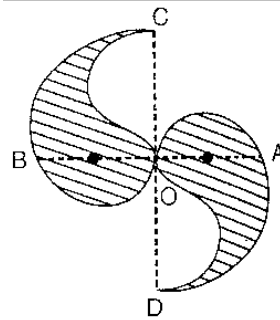

20. The adjoining figure shows the cross-section of a railway tunnel.
 The radius of the tunnel is 3.5m (i.e., $OA=3.5\text{m}$) and $\angle AOB=90^\circ$.
 Calculate :

- the height of the tunnel.
- the perimeter of its cross section, including base.
- the area of the cross-section
- the internal surface area of the tunnel, excluding base, if its length is 50m.

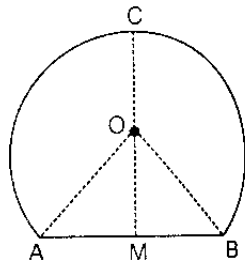

(Ans: (i) 5.97m (ii) 21.44m (iii) 28.875 sq m (iv) 825 sq m)

Ans: Self Practice

21. In the adjoining figure, ABCD is a square of side 6cm. Find the area of the shaded region.

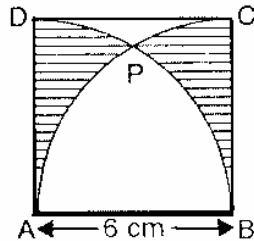

(Ans: 34.428 sq cm)

Ans: From P draw $PQ \perp AB$

$$AQ = QB = 3\text{cm}$$

Join PB. Since arc APC is described by a circle with center B,
 so $BA = BP = BC = 6\text{cm}$.

$$\text{In } \Delta PQB \cos \theta = \frac{QB}{PB} = \frac{1}{2}$$

$$\therefore \theta = 60^\circ$$

$$\text{Area of sector BPA} = \frac{60}{360} \Pi (6^2) = 18.84 \text{ cm}$$

$$\text{Area of } \Delta \text{ BPQ} = \frac{1}{2} (\text{QB}) (\text{PQ}) = \frac{1}{2} (3) (6 \sin 60) = 7.794 \text{ Sq.cm}$$

$$\begin{aligned} \rightarrow \text{Area of portion APQ} &= \text{Area of sector BPA} - \text{Area of } \Delta \text{ BPQ} \\ &= 18.84 - 7.794 = 11.046 \text{ Sq.cm} \end{aligned}$$

$$\text{Area of shaded portion} = 2 \times \text{Area of Quadrant ABC} - 2 \times \text{Area APQ}$$

$$= \left[2 \times \frac{\Pi}{4} (6)^2 - 2 \times 11.046 \right]$$

$$= 34.428 \text{ Sq.cm}$$

22. In the adjoining figure, ABCD is a rectangle with sides 4cm and 8cm. Taking 8cm as the diameter, two semicircles are drawn. Find the area overlapped by the two semicircles.

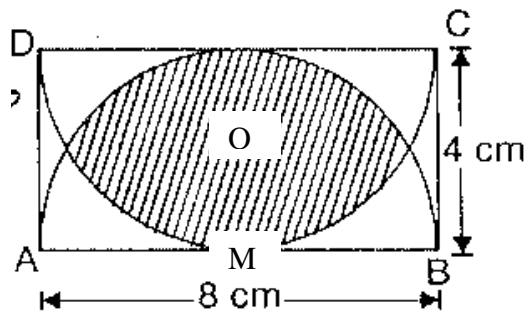

(Ans: 19.66 sq cm)

Ans: In $\Delta \text{ OMB}$

$$\cos \angle \text{BOM} = \frac{\text{OM}}{\text{OB}} = \frac{2}{4} = \frac{1}{2}$$

$$\therefore \angle \text{BOM} = 60^\circ$$

$$\angle \text{AOB} = 120^\circ$$

Area. Overlapped by semi circles

$$= 2 \left(\frac{120}{360} \times \Pi (4^2) - \frac{1}{2} \text{ AB} \times \text{OM} \right)$$

$$= 2 \left(\frac{\Pi}{3} \times 16 - \frac{1}{2} (2 \times \text{AM} \sin 60^\circ) \times 2 \right)$$

$$= 2 \left(\frac{22}{7} \times \frac{1}{3} \times 16 - 2 \times 4 \times \frac{\sqrt{3}}{2} \right)$$

$$= 2 (16.76 - 6.93) = 19.66 \text{ Sq. cm}$$

UNIT-12

PROBLEMS BASED ON CONVERSION OF SOLIDS

1. A solid is in the form of a right circular cone mounted on a hemisphere. The radius of the hemisphere is 3.5 cm and the height of the cone is 4 cm. The solid is placed in a cylindrical tub, full of water, in such a way that the whole solid is submerged in water. If the radius of the cylindrical tub is 5 cm and its height is 10.5 cm, find the volume of water left in the cylindrical tub (use $\pi = \frac{22}{7}$]

(Ans: 683.83 cm³)

Ans: No. of solid = vol of cone + vol of hemisphere

$$\begin{aligned} &= \frac{1}{3} \pi r^2 h + \frac{2}{3} \pi r^3 \\ &= \frac{1}{3} \pi r^2 [h + 2r] \end{aligned}$$

On substituting we get,
= 141.17 cm³

vol of cylinder = $\pi r^2 h$

$$\begin{aligned} &\text{On substituting we get,} \\ &= 825 \text{ cm}^3 \end{aligned}$$

$$\begin{aligned} \text{volume of H}_2\text{O left in the cylinder} &= 825 - 141.17 \\ &= 683.83 \text{ cm}^3 \end{aligned}$$

2. A bucket of height 8 cm and made up of copper sheet is in the form of frustum of right circular cone with radii of its lower and upper ends as 3 cm and 9 cm respectively. Calculate
- i) the height of the cone of which the bucket is a part
 - ii) the volume of water which can be filled in the bucket
 - iii) the area of copper sheet required to make the bucket (Leave the answer in terms of π cm²)
- (Ans: 129 π)

Ans: Let total height be h

$$\Rightarrow \frac{h}{h+8} = \frac{3}{9} \text{ (similar } \Delta\text{'s)}$$

$$\Rightarrow h = 4 \text{ cm}$$

\therefore ht. of cone which bucket is a part = 4 cm

Substitute to get Ans.: for ii) iii)

3. A sphere and a cube have equal surface areas. Show that the ratio of the volume of the sphere to that of the cube is $\sqrt{6} : \sqrt{\pi}$.

Ans: S.A. of sphere = S.A. of cube

$$\Rightarrow 4\pi r^2 = 6a^2$$

$$\Rightarrow r = \sqrt{\frac{6a^2}{4\pi}}$$

$$\therefore \text{ratio of their volume } \frac{v_1}{v_2} = \frac{\frac{4}{3}\pi r^3}{a^3}$$

On simplifying & substituting, we get $\sqrt{6} : \sqrt{\pi}$

4. A right triangle whose sides are 15 cm and 20 cm is made to revolve about its hypotenuse. Find the volume and surface area of the double cone so formed.

(Ans : 3768cu.cm,1318.8 Sq.cm)

Ans: $BC = \sqrt{15^2 + 20^2} = 25 \text{ cm}$

Apply Py. Th to right ΔOAB & OAC to get $OB = 9\text{cm}$ $OA = 12\text{cm}$

$$\begin{aligned} \text{Vol of double cone} &= \text{vol of } CAA^1 + \text{vol of } BAA^1 \\ &= \frac{1}{3} \pi \times 12^2 \times 16 + \frac{1}{3} \pi \times 12^2 \times 9 \\ &= 3768 \text{ cm}^3 \end{aligned}$$

$$\begin{aligned} \text{SA of double cone} &= \text{CSA of } CAA^1 + \text{CSA of } BAA^1 \\ &= \pi \times 12 \times 20 + \pi \times 12 \times 15 \\ &= 1318.8 \text{ cm}^2 \end{aligned}$$

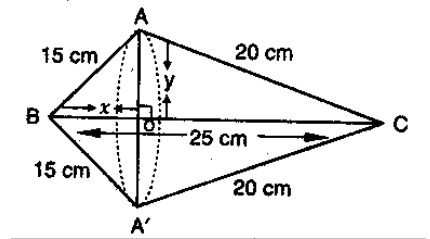

5. Water in a canal 30 dm wide and 12 dm deep is flowing with a velocity of 10 km/h. How much area will it irrigate in 30 minutes if 8 cm of standing water is required for irrigation? (Ans:

225000 cu. m)

Ans: Width of canal = 30 dm = 3m

Depth of canal = 1.2 m

Velocity = 10 km / h = 10000 m/h

Length of water column is formed in 30 min = $10000 \times \frac{1}{2} = 5000 \text{ m}$

$$\begin{aligned} \text{Let } x\text{m}^2 \text{ of area be irrigated} &\Rightarrow x \times \frac{8}{100} = 5000 \times 1.2 \times 3 \\ &\Rightarrow x = 225000 \text{ m}^2 \end{aligned}$$

6. A cylindrical vessel of diameter 14 cm and height 42 cm is fixed symmetrically inside a similar vessel of diameter 16 cm and height 42 cm. The total space between two vessels is filled with cork dust for heat insulation purposes. How many cubic centimetres of cork dust will be required?
(Ans: 1980 cu.cm)

Ans: volume of cork dust required = $\pi R^2 h - \pi r^2 h$
 $= \pi 42 [64 - 49]$
 $= 1980 \text{ cm}^3$

7. An ice-cream cone has a hemispherical top. If the height of the cone is 9 cm and base radius is 2.5 cm, find the volume of ice cream cone. (Ans: $91 \frac{2}{3}$ cu.cm)

Ans: Do yourself

8. A building is in the form of a cylinder surrounded by a hemispherical vaulted dome and contains $41 \frac{19}{21}$ cu m of air. If the internal diameter of the building is equal to its total height above the floor, find the height of the building.
(Ans : 4m)

Ans: Volume of building = $41 \frac{19}{21} \text{ m}^3$
 $\Rightarrow \pi r^2 \cdot r + \frac{2}{3} \pi r^3 = 41 \frac{19}{21}$
 $\Rightarrow \pi \times r^3 \times \frac{5}{3} = \frac{880}{21}$
 $\Rightarrow r^3 = \frac{880}{21} \times \frac{7}{22} \times \frac{3}{5}$
 $\Rightarrow r^3 = 8$
 $\Rightarrow r = 2 \text{ m}$
 $\therefore \text{height of building} = 4 \text{ cm}$

9. The height of the Cone is 30 cm A small cone is cut off at the top by a plane parallel to its base if its volume be $\frac{1}{27}$ of the volume of the given cone at what height above the base is the section cut
(Ans:20 cm)

Ans: $\Delta VO'B \sim \Delta VOB$

$$\therefore \frac{H}{h} = \frac{R}{r} = \frac{30}{h} = \frac{R}{r} \text{ ----(1)}$$

APQ: vol of cone $VA'B' = \frac{1}{27}$ (vol of cone VAB)

$$\Rightarrow \frac{1}{3} \pi r^2 h = \frac{1}{27} \left(\frac{1}{3} \pi R^2 H \right)$$

$$\Rightarrow h^3 = 1000 \text{ (using (1))}$$

$$h = 10 \text{ cm}$$

$$\therefore \text{height at which section is made } (30 - 10) = 20 \text{ cm}$$

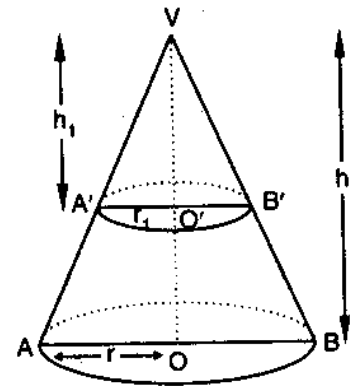

10. A hollow cone is cut by a plane parallel to the base and the upper portion is removed. If the curved surface of the remainder is $\frac{8}{9}$ th of the curved surface of the whole cone, find the ratio of the line segments into which the cone's altitude is divided by the plane.

(Ans:1:2)

We know that $\Delta VO'B \sim \Delta VOB$

$$\frac{h}{H} = \frac{r}{R} = \frac{l}{L}$$

C. SA of frustum = $\frac{8}{9}$ (CSA of the cone)

$$\Pi (R+r) (L-l) = \frac{8}{9} \Pi RL$$

$$\Rightarrow \left(\frac{R+r}{R} \right) \left(\frac{L-l}{L} \right) = \frac{8}{9}$$

$$\Rightarrow \left(1 + \frac{r}{R} \right) \left(1 - \frac{l}{L} \right) = \frac{8}{9}$$

$$\Rightarrow \left(1 + \frac{h}{H} \right) \left(1 - \frac{h}{H} \right) = \frac{8}{9}$$

On simplifying we get $\frac{h^2}{H^2} = \frac{1}{9}$

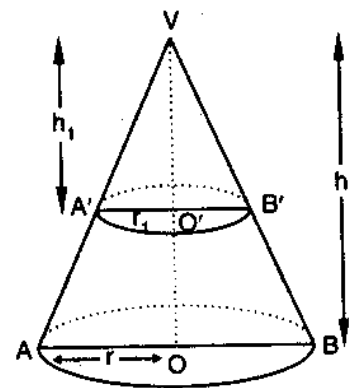

$$\frac{h}{H} = \frac{1}{3}$$

$$\Rightarrow H = 3h$$

$$\text{required ratios} = \frac{h}{H-h} = \frac{1}{2}$$

11. Two right circular cones X and Y are made X having 3 times the radius of Y and Y having half the Volume of X. Calculate the ratio of heights of X and Y. (Ans: 9 : 2)

Ans: Let radius of cone X = r
Radius of Cone Y = 3r

$$V \text{ of Y} = \frac{1}{2} \text{ volume of X}$$

$$\frac{1}{3} \pi r^2 h_1 = \frac{1}{2} \left(\frac{1}{3} \pi r^2 h_2 \right)$$

$$\Rightarrow r^2 h_1 = \frac{1}{2} 9 r^2 h_2$$

$$\frac{h_1}{h_2} = \frac{9r^2}{2r^2}$$

$$\frac{h_1}{h_2} = \frac{9}{2}$$

12. If the areas of three adjacent faces of cuboid are x, y, z respectively, Find the volume of the cuboids.

Ans: lb = x, bh = y, hl = z

Volume of cuboid = lbh

$$V^2 = l^2 b^2 h^2 = xyz$$

$$V = \sqrt{xyz}$$

13. A shuttlecock used for playing badminton has the shape of a frustum of a Cone mounted on a hemisphere. The external diameters of the frustum are 5 cm and 2 cm, and the height of the entire shuttlecock is 7cm. Find the external surface area.

(Ans: 74.26cm²)

Ans: r₁ = radius of lower end of frustum = 1 cm

r₂ = radius of upper end = 2.5 cm

h = ht of frustum = 6cm

$$l = \sqrt{h^2 + (r_2 - r_1)^2} = 6.18 \text{ cm}$$

$$\text{External surface area of shuttlecock} = \pi (r_1 + r_2) l + 2\pi r_1^2$$

On substituting we get, $= 74.26 \text{ cm}^2$

14. A Solid toy in the form of a hemisphere surmounted by the right circular cone of height 2cm and diameter of the base 4 cm .If a right circular cylinder circumscribes the toy, find how much more space than the toy it will cover.

(Ans: 8π)

Ans : Self practice

15. A conical vessel of radius 6cm and height 8cm is completely filled with water. A sphere is lowered into the water and its size is such that when it touches the sides, it is just immersed as shown in the figure. What fraction of water flows out.

[Ans: $\frac{3}{8}$]

Ans: This problem can be done in many ways

Let "r" be the radius of sphere

In right triangle

$$\tan \theta = \frac{6}{8} = \frac{3}{4}$$

$$\Rightarrow \sin \theta = \frac{3}{5}$$

in rt Δ

$$\sin \theta = \frac{r}{VO} = \frac{3}{5} = \frac{r}{8-r}$$

$$r = 3 \text{ cm}$$

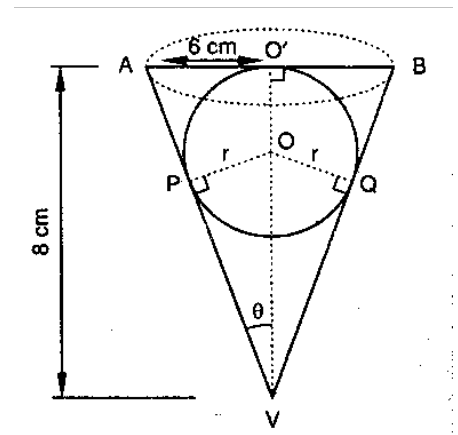

Volume of H_2O that flows out of cone = volume of sphere

$$\text{fraction of water Overflows} = \frac{\text{volume f sphere}}{\text{Volume of cone}}$$

$$= \frac{36\pi}{96\pi} = \frac{3}{8}$$

16. A golf ball has a diameter equal to 4.1cm. Its surface has 150 dimples each of radius 2mm. Calculate the total surface area which is exposed to the surroundings assuming that the dimples are hemispherical.

(Ans: 71.68)

Ans: SA of ball = $4\pi \times \left(\frac{4.1}{2}\right)^2 = 16.8\pi \text{ cm}^2$

TSA exposed to surroundings

$$= \text{SA of ball} - 150 \times \pi r^2 + 150 \times 2\pi r^2$$

$$= 16.8\pi + 150\pi r^2$$

$$= 71.68 \text{ cm}^2$$

17. A solid metallic circular cone 20cm height with vertical angle 60 is cut into two parts at the middle point of its height by a plane parallel to the base. If the frustum, so obtained be drawn into a wire of diameter $\frac{1}{16}$ cm Find the length of the wire. (Ans:7964.4m)

Ans: Let r_1 & r_2 be the two ends of the frustum $\frac{r_1}{20} = \tan 30$

$$r_1 = \frac{20}{\sqrt{3}}; r_2 = \frac{10}{\sqrt{3}} \text{ cm}$$

$$\begin{aligned} \text{volume of frustum} &= \frac{1}{3} \pi h (r_1^2 + r_2^2 + r_1 r_2) \\ &= \frac{1}{3} \pi \times 10 \left(\frac{400}{3} + \frac{100}{3} + \frac{200}{3} \right) \text{ cm} \end{aligned}$$

Since the frustum is drawn into a wire of length x

Volume of frustum = volume of cylinder

$$\frac{1}{3} \pi \times 10 \times \frac{700}{3} = \pi \left(\frac{1}{32} \right)^2 \times x$$

$$\Rightarrow x = \frac{7168000}{9} \text{ cm}$$

$$x = 7964.4 \text{ m}$$

18. If the areas of the circular bases of a frustum of a cone are 4cm^2 and 9cm^2 respectively and the height of the frustum is 12cm. What is the volume of the frustum. (Ans:44cm³).

Ans: Self practice

19. The lower portion of a hay stack is an inverted cone frustum and the upper part is a cone find the total volume of the hay stack.

135.67cu cm)

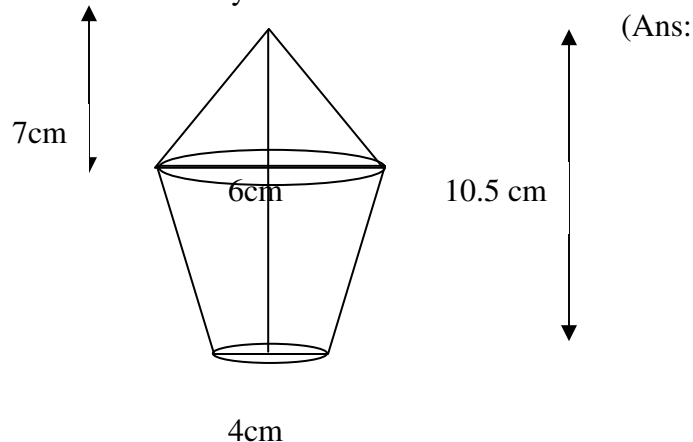

Ans: Self practice

20. A vessel in shape of a inverted cone is surmounted by a cylinder has a common radius of 7cm this was filled with liquid till it covered one third the height of the cylinder. If the height of each part is 9cm and the vessel is turned upside down. Find the volume of the liquid and to what height will it reach in the cylindrical part. (Ans:924 π cu cm, 6cm)

Ans: Volume of liquid in the vessel = $\frac{1}{3} \pi (7)^2 (9) + \pi (7)^2 (3)$

= 924 cu cm

height of cylindrical part = $\frac{924}{\frac{22}{7} \times 49} = 6$ cm

UNIT 13

STATISTICS AND PROBABILITY

Statistics are the only tools by which an opening can be cut through the formidable thicket of difficulties that bars the path of those who pursue the Science of Man.

1. Marks obtained by 70 students are given below:

Marks	20	70	50	60	75	90	40
No. of Students	8	12	18	6	9	5	12

Find the median.

(Ans:50)

Ans:

Marks	No . of students	c.f
20	8	8
40	12	20
50	18	38
60	6	44

70	12	53
75	9	58
90	5	70

$N = 70$

$$\frac{N}{2} = \frac{70}{2} = 35$$

The corresponding value of marks for 35 is 50

2. The sum of deviations of a set of values $x_1, x_2, x_3, \dots, x_n$, measured from 50 is -10 and the sum of deviations of the values from 46 is 70.

Find the value of n and the mean. (Ans:20,.49.5)

Ans: We have

$$\sum_{i=1}^n (X_i - 50) = -10 \text{ and } \sum_{i=1}^n (X_i - 46) = 70$$

$$\sum_{i=1}^n X_i - 50n = -10 \quad \dots\dots\dots (1)$$

$$\text{and } \sum_{i=1}^n X_i - 46n = 70 \quad \dots\dots\dots(2)$$

subtracting (2) from (1), we get

$$-4n = -80 \text{ we get } n = 20$$

$$\sum_{i=1}^n X_i - 50 \times 20 = -10$$

$$\sum_{i=1}^n X_i = 990$$

$$\text{Mean} = \frac{1}{n} \left(\sum_{i=1}^n X_i \right) = \frac{990}{20} = 49.5$$

hence $n = 20$ and mean = 49.5

3. Prove that $\sum(x_i - \bar{x}) = 0$

Ans: To prove $\sum_{i=1}^n (X_i - \bar{X}) = 0$ algebraic sum of deviation from mean is zero

$$\text{We have, } \bar{X} = \frac{1}{n} \left(\sum_{i=1}^n X_i \right)$$

$$n\bar{X} = \sum_{i=1}^n X_i$$

$$\text{Now, } \sum_{i=1}^n (X_i - \bar{X}) = (X_1 - \bar{X}) + (X_2 - \bar{X}) + \dots\dots\dots + (X_n - \bar{X})$$

$$\sum_{i=1}^n (X_i - \bar{X}) = (X_1 + X_2 + \dots\dots\dots + X_n) - n\bar{X}$$

$$\sum_{i=1}^n (X_i - \bar{X}) = \sum_{i=1}^n X_i - n\bar{X}$$

$$\sum_{i=1}^n (X_i - \bar{X}) = n\bar{X} - n\bar{X}$$

$$\sum_{i=1}^n (X_i - \bar{X}) = 0$$

$$\text{Hence, } \sum_{i=1}^n (X_i - \bar{X}) = 0$$

4. Compute the median from the following data

Mid value	115	125	135	145	155	165	175	185	195
Frequency	6	25	48	72	116	60	38	22	3

(Ans:135.8)

Ans: Here, we are given the mid values. So, we should first find the upper and lower limits of the various classes. The difference between two consecutive values is $h = 125 - 115 = 10$

\therefore Lower limit of a class = Midvalue - $h/2$

Upper limit = Midvalue + $h/2$

Calculate of Median

Mid - value	Class Groups	Frequency	Cumulative frequency
115	110-120	6	6
125	120-130	25	31
135	130-140	48	79
145	140-150	72	151
155	150-160	116	267
165	160-170	60	327
175	170-180	38	365
185	180-190	22	387
195	190-200	3	390
			$N = \sum f_i = 390$

We have,

$$N = 390 \quad \therefore N/2 = 390/2 = 195$$

The cumulative frequency first greater than $N/2$ i.e. 195 is 267 and the corresponding class is 150 – 160, so, 150 – 160 is the median class.

$$L = 150, f = 116, h = 10, f = 151$$

Now,

$$\text{Median} = L + \frac{\frac{n}{2} - f}{f} \times h$$

$$\text{Median} = 150 + \frac{195 - 151}{116} \times 10 = 153.8$$

5. The mean of 'n' observation is \bar{x} , if the first term is increased by 1, second by 2 and so on. What will be the new mean. (Ans: $\bar{x} + \frac{n+1}{2}$)

Ans: I term + 1
II term + 2
III term + 3
.
.
n term + n

$$\text{The Mean of the new numbers is } \bar{X} + \frac{\frac{n(n+1)}{2}}{n} = \bar{X} + \frac{(n+1)}{2}$$

6. In a frequency distribution mode is 7.88, mean is 8.32 find the median. (Ans: 8.17)

Ans: Mode = 3 median - 2 mean
 $7.88 = 3 \text{ median} - 2 \times 8.32$
 $7.88 + 16.64 = 3 \text{ median}$
 $\frac{24.52}{3} = \text{median}$
 $\therefore \text{median} = 8.17$

7. The mode of a distribution is 55 & the modal class is 45-60 and the frequency preceding the modal class is 5 and the frequency after the modal class is 10. Find the frequency of the modal class. (Ans: 15)

Ans: mode = 55
Modal class = 45 - 60
Modal class preceding $f_1 = 5$
After the modal class = $f_2 = 10$

$$\text{Mode} = L + \frac{f - f_1}{2f - f_1 - f_2} \times h$$

$$55 = 45 + \frac{f-5}{2f-5-10} \times 15$$

$$10 = \left(\frac{f-5}{2f-15}\right) \times 15$$

$$\frac{10}{15} = \frac{f-5}{2f-15}$$

$$20f - 150 = 15f - 75$$

$$5f = 75$$

$$f = \frac{75}{5} = 15$$

8. The mean of 30 numbers is 18, what will be the new mean, if each observation is increased by 2? (Ans:20)

Ans: Let $x_1, x_2, x_3, \dots, x_{30}$ be 30 number with then mean equal to 18 then

$$\bar{X} = \frac{1}{n} (\sum x_i)$$

$$18 = \frac{x_1 + x_2 + x_3 + \dots + x_{30}}{30}$$

$$x_1 + x_2 + x_3 + \dots + x_{30} = 18 \times 30 = 540$$

New numbers are $x_1 + 2, x_2 + 2, x_3 + 2, \dots, x_{30} + 2$

Let \bar{X} be the mean of new numbers

$$\text{then } \bar{X} = \frac{(x_1 + 2) + (x_2 + 2) + \dots + (x_{30} + 2)}{30}$$

$$\bar{X} = \frac{\frac{n(n+1)}{2}}{n}$$

$$\bar{X} = \frac{n+1}{2}$$

$$\frac{(x_1 + x_2 + \dots + x_{30}) + 2 \times 30}{30} = \frac{540 + 60}{30}$$

$$\text{Mean of new numbers} = \frac{600}{30} = 20$$

9. In the graphical representation of a frequency distribution if the distance between mode and mean is k times the distance between median and mean then find the value of k. (Ans:k=3)

Self Practice

10. Find the mean of 30 numbers given mean of ten of them is 12 and the mean of remaining 20 is 9. (Ans:10)

Ans: Total number of mean = 30

Mean of 10 is = 12

$$12 = \frac{\sum_{i=1}^n X_i}{10}$$

$$\sum X_i = 12 \times 10 = 120 \quad \text{---(1)}$$

Mean of 20 numbers is = 9

$$9 = \frac{\sum X_i}{20}$$

$$9 \times 20 = \sum_{i=1}^n X_i \quad \text{----- (2)}$$

$$180 = \sum X_i$$

(1) + (2)

$$\text{Mean of 20 numbers} = \frac{120 + 180}{30}$$

$$= \frac{300}{30} = 10$$

PROBABILITY

Life is a school of probability.

1. An integer is chosen at random from the first two hundreds digit. What is the probability that the integer chosen is divisible by 6 or 8. (Ans : $\frac{1}{4}$)

Ans: Multiples of 6 first 200 integers
6, 12, 18, 24, 30, 36, 42, 48, 54, 60, 66, 72, 78, 84, 90, 96, 102, 108, 114,
120, 126, 132, 138, 144, 150, 156, 162, 168, 174, 180, 186, 192, 198

Multiples of 8 first 200 integers
8, 16, 24, 32, 40, 48, 56, 64, 72, 80, 88, 96, 104, 112, 120, 128, 136, 144, 152, 160,
168, 176, 184, 192, 200

Number of Multiples of 6 or 8 = 50
 $P(\text{Multiples of 6 or 8}) = 50 / 200 = 1/4$

2. A box contains 12 balls out of which x are black .if one ball is drawn at random from the box what is the probability that it will be a black ball ? If 6 more black balls are put in the box ,the probability of drawing a black ball is now double of what it was before. Find x. (Ans: x = 3)

Ans: Random drawing of balls ensures equally likely outcomes

Total number of balls = 12

Total number pf possible outcomes = 12

Number of black balls = x

(1) out of total 12 outcomes, favourable outcomes = x

$$P(\text{black ball}) = \frac{\text{Number of favourable outcomes}}{\text{Total number of possible outcomes}} = \frac{x}{12}$$

Total number of possible outcomes

(2) if 6 more black balls are put in the bag, then

The total number of black balls = x + 6

Total number of balls in the bag = 12 + 6 = 18

According to the question

Probability of drawing black ball is second case

= 2 X probability drawing of black ball in first case

$$\frac{x+6}{18} = 2 \left(\frac{x}{12} \right)$$

$$\frac{x+6}{18} = \frac{x}{6}$$

$$6x + 36 = 18x$$

$$x = 3$$

hence number of black balls = 3

3. A bag contains 8 red balls and x blue balls, the odd against drawing a blue ball are 2: 5. What is the value of x ? (Ans:20)

Ans: No. of blue balls be x
 No. of red balls be 8
 Total no. of balls = $x + 8$

$$\text{Probability of drawing blue balls} = \frac{x}{8+x}$$

$$\text{Probability of drawing red balls} = \frac{8}{8+x}$$

$$\frac{8}{8+x} : \frac{x}{8+x} = 2 : 5$$

$$2 \left(\frac{x}{8+x} \right) = 5 \left(\frac{8}{8+x} \right)$$

$$2x = 40$$

$$\therefore x = 20$$

4. A card is drawn from a well shuffled deck of cards
 (i) What are the odds in favour of getting spade? (Ans: 1:3, 3:1, 3:10, 1:25)
 (ii) What are the odds against getting a spade?
 (iii) What are the odds in favour of getting a face card?
 (iv) What are the odds in favour of getting a red king

Ans: Total cards 52
 Spade = 13
 Remaining cards 39

- i) The odds in favour of getting spade 13
 The odds is not in favour of getting spade 39

$$= \frac{13}{52} : \frac{39}{52} = 1 : 3$$

- ii) The odds against getting a spade 39

The odds not against getting a spade 13

$$= \frac{39}{52} : \frac{13}{52} = 3 : 1$$

iii) The odds in favour of getting a face card 12

The odds not in favour of getting a face card 40

$$= \frac{12}{52} : \frac{40}{52} = 3 : 10$$

iv) The odds in favour of getting a red king 2

The odds not in favour of getting a red king 50

$$= \frac{2}{52} : \frac{50}{52} = 1 : 25$$

- 5 A die is thrown repeatedly until a six comes up. What is the sample space for this experiment? HINT ;A= {6} B={1,2,3,4,5,}

Ans: The sample space is = {A, BA, BBA, BBBA, BBBBA.....}

6. Why is tossing a coin considered to be a fair way of deciding which team should get the ball at the beginning of a foot ball match?

Ans: equally likely because they are mutually exclusive events .

7. A bag contains 5 red balls and some blue balls. If the probability of drawing a blue ball is double that of a red ball , determine the number of blue balls in the bag. (Ans:10)

Ans: Let the number of blue balls in the bag be x

Then total number of balls in the bag = 5 + x

∴ Number of all possible outcomes = 5 + x

Number of outcomes favourable to the event of drawing a blue ball = x

(Q there are x blue balls)

∴ Probability of drawing a blue ball $\frac{x}{5+x}$

Similarly, probability of drawing a red ball = $\frac{5}{5+x}$

According to the answer

$$\frac{x}{5+x} = 2 \left(\frac{5}{5+x} \right)$$

$$x = 10$$

8. A box contains 12 balls out of which x are black. If one ball is drawn at random from the box, what is the probability that it will be a black ball? If 6 more black balls are put in the box the probability of drawing a black ball is now double of what it was before. Find x ? (Ans: 3)

Ans: Number of all possible outcomes = 12

Number of outcomes favourable to the event of drawing black ball = x

$$\text{Required probability} = \frac{x}{12}$$

Now when 6 more black balls are put in the box,

Number of all possible outcomes = $12 + 6 = 18$

Number of outcomes favourable to the event of drawing a black ball = $x + 6$

$$\therefore \text{Probability of drawing a black ball} = \frac{x+6}{18}$$

According to the question,

$$\frac{x+6}{18} = 2 \left(\frac{x}{12} \right)$$

$$\therefore x = 3$$

9. If 65% of the populations have black eyes, 25% have brown eyes and the remaining have blue eyes. What is the probability that a person selected at random has (i) Blue eyes (ii) Brown or black eyes (iii) Blue or black eyes (iv) neither blue nor brown eyes (Ans: $\frac{1}{10}, \frac{9}{10}, \frac{3}{4}, \frac{13}{20}$)

Ans: No. of black eyes = 65
 No. of Brown eyes = 25
 No. of blue eyes = 10
 Total no. of eyes = 180

$$\text{i) } P(\text{Blue eyes}) = \frac{10}{180} = \frac{1}{18}$$

$$\text{ii) } P(\text{Brown or black eyes}) = \frac{90}{180} = \frac{1}{2}$$

$$\text{iii) } P(\text{Blue or black eyes}) = \frac{75}{180} = \frac{5}{12}$$

$$\text{iv) } P(\text{neither blue nor brown eyes}) = \frac{65}{180} = \frac{13}{36}$$

10. Find the probability of having 53 Sundays in
 (i) a leap year (ii) a non leap year (Ans: $\frac{2}{7}, \frac{1}{7}$)

Ans: An ordinary year has 365 days i.e. 52 weeks and 1 day
 This day can be any one of the 7 days of the week.

$$\therefore P(\text{that this day is Sunday}) = \frac{1}{7}$$

$$\text{Hence, } P(\text{an ordinary year has 53 Sunday}) = \frac{1}{7}$$

A leap year 366 days i.e. 52 weeks and 2 days
 This day can be any one of the 7 days of the week

$$\therefore P(\text{that this day is Sunday}) = \frac{2}{7}$$

$$\text{Hence, } P(\text{a leap year has 53 Sunday}) = \frac{2}{7}$$

11. Find the probability that the month June may have 5 Mondays in
 (i) a leap year (ii) a non leap year (Ans: $\frac{2}{7}, \frac{2}{7}$)

Self Practice

12. Find the probability that the month February may have 5 Wednesdays in
 (i) a leap year (ii) a non leap year (Ans: $\frac{1}{7}, 0$)

Self Practice

13. Five cards – the ten, jack, queen, king and ace, are well shuffled with their face downwards. One card is then picked up at random.
 (i) What is the probability that the card is a queen?
 (ii) If the queen is drawn and put aside, what is the probability that the second card picked up is a (a) an ace (b) a queen (Ans: $\frac{1}{5}, \frac{1}{4}, 0$)

Ans : Here, the total number of elementary events = 5
 (i) Since, there is only one queen
 \therefore Favourable number of elementary events = 1
 \therefore Probability of getting the card of queen = $\frac{1}{5}$
 (ii) Now, the total number of elementary events = 4
 (a) Since, there is only one ace
 \therefore Favourable number of elementary events = 1

$$\therefore \text{Probability of getting an ace card} = \frac{1}{4}$$

(b) Since, there is no queen (as queen is put aside)

$$\therefore \text{Favourable number of elementary events} = 0$$

$$\therefore \text{Probability of getting a queen} = \frac{0}{4} = 0$$

14. A number x is chosen at random from the numbers $-3, -2, -1, 0, 1, 2, 3$. What is the probability that $|x| < 2$ (Ans: $\frac{3}{7}$)

Ans : x can take 7 values

To get $|x| < 2$ take $-1, 0, 1$

$$\text{Probability} (|x| < 2) = \frac{3}{7}$$

15. A number x is selected from the numbers $1, 2, 3$ and then a second number y is randomly selected from the numbers $1, 4, 9$. What is the probability that the product xy of the two numbers will be less than 9? (Ans: $\frac{5}{9}$)

Ans : Number X can be selected in three ways and corresponding to each such way there are three ways of selecting number y . Therefore, two numbers can be selected in 9 ways as listed below:

$(1, 1), (1, 4), (2, 1), (2, 4), (3, 1)$

\therefore Favourable number of elementary events = 5

$$\text{Hence, required probability} = \frac{5}{9}$$

16. In the adjoining figure a dart is thrown at the dart board and lands in the interior of the circle. What is the probability that the dart will land in the shaded region.

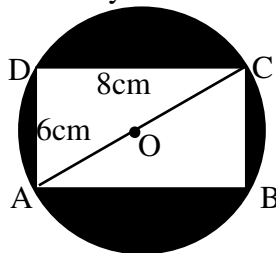

$$\left[\text{Ans: } \frac{25\pi - 48}{25\pi} \right]$$

Ans: We have

$$AB = CD = 8 \text{ and } AD = BC = 6$$

using Pythagoras Theorem in $\triangle ABC$, we have

$$AC^2 = AB^2 + BC^2$$

$$AC^2 = 8^2 + 6^2 = 100$$

$$AC = 10$$

$$OA = OC = 5 \quad [\text{Q } O \text{ is the midpoint of } AC]$$

\therefore Area of the circle = $\pi (OA)^2 = 25 \pi$ sq units [Q Area = πr^2]
 Area of rectangle ABCD = AB x BC = 8 x 6 = 48 sq units
 Area of shaded region = Area of the circle – Area of rectangle ABCD
 Area of shaded region = $25 \pi - 48$ sq unit.
 Hence

$$P(\text{Dart lands in the shaded region}) = \frac{\text{Area of shaded region}}{\text{Area of circle}} = \frac{25\pi - 48}{25\pi}$$

17. In the fig points A ,B ,C and D are the centres of four circles ,each having a radius of 1 unit . If a point is chosen at random from the interior of a square ABCD ,what is the probability that the point will be chosen from the shaded region .

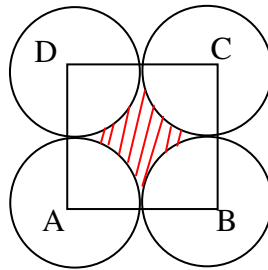

(Ans: $\frac{4 - \pi}{4}$)

Ans: Radius of the circle is 1 unit
 Area of the circle = Area of 4 sector
 $\pi r^2 = \pi \times 1^2 = \pi$
 Side of the square ABCD = 2 units
 Area of square = 2 x 2 = 4 units
 Area shaded region is
 = Area of square – 4 x Area of sectors
 = 4 - π

$$\text{Probability} = \left(\frac{4 - \pi}{4} \right)$$

18. In the adjoining figure ABCD is a square with sides of length 6 units points P & Q are the mid points of the sides BC & CD respectively. If a point is selected at random from the interior of the square what is the probability that the point will be chosen from the interior of the triangle APQ.

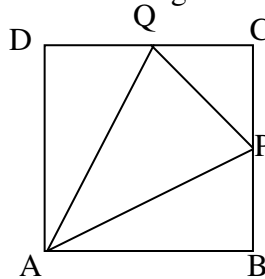

(Ans: $\frac{3}{8}$)

Ans: Area of triangle PQC = $\frac{1}{2} \times 3 \times 3 = \frac{9}{2} = 4.5$ units

$$\text{Area of triangle ABP} = \frac{1}{2} \times 6 \times 3 = 9$$

$$\text{Area of triangle ADQ} = \frac{1}{2} \times 6 \times 3 = 9$$

Area of triangle APQ = Area of a square – (Area of a triangle PQC + Area of triangle

ABP + Area of triangle ABP)

$$\begin{aligned} &= 36 - (18+4.5) \\ &= 36 - 22.5 \\ &= 13.5 \end{aligned}$$

$$\begin{aligned} \text{Probability that the point will be chosen from the interior of the triangle APQ} &= \frac{13.5}{36} \\ &= \frac{135}{360} = \frac{3}{8} \end{aligned}$$

19. In a musical chair game the person playing the music has been advised to stop playing the music at any time within 2 minutes after she starts playing. What is the probability that the music will stop within the half minute after starting.

(Ans: $\frac{1}{4}$)

Ans: Here the possible outcomes are all the numbers between 0 and 2.

This is the portion of the number line from 0 to 2 as shown in figure.

Let A be the event that ‘the music is stopped within the first half minute.’ Then, outcomes favorable to event A are all points on the number line from O to Q i.e., from 0 to $\frac{1}{2}$.

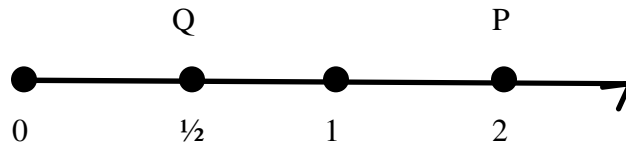

The total number of outcomes are the points on the number line from O to P i.e., 0 to 2.

$$\therefore P(A) = \frac{\text{Length of OQ}}{\text{Length of OP}} = \frac{1/2}{2} = \frac{1}{4}$$

20. A jar contains 54 marbles each of which is blue , green or white. The probability of selecting a blue marble at random from the jar is $\frac{1}{3}$ and the probability of selecting a green marble at random is $\frac{4}{9}$. How many white marbles does the jar contain? (Ans:12)

Ans: Let there be b blue, g green and w white marbles in the marbles in the jar. Then,

$$b + g + w = 54$$

$$\therefore P(\text{Selecting a blue marble}) = \frac{b}{54}$$

It is given that the probability of selecting a blue marble is $\frac{1}{3}$.

$$\therefore \frac{1}{3} = \frac{b}{54} \Rightarrow b = 18$$

We have,

$$P(\text{Selecting a green marble}) = \frac{4}{9}$$

$$\Rightarrow \frac{g}{54} = \frac{4}{9} \quad [\text{Q } P(\text{Selecting a green marble}) = \frac{4}{9} \text{ (Given)}]$$

$$\Rightarrow g = 24$$

Substituting the values of b and g in (i), we get

$$18 + 24 + w = 54 \Rightarrow w = 12$$

